



SERIAL NUMBER

**AN SPX DIVISION**



# **FTB 360i-2 LED Integrated Beacon**

**Reference Manual  
Part Number 7913602**

Flash Technology, 332 Nichol Mill Lane, Franklin, TN 37067  
(615) 261-2000

## **Front Matter**

### ***Abstract***

This manual contains information and instructions for installing, operating and maintaining the FTB 360i-2 LED Integrated L-864 Beacon.

### ***Copyright***

Copyright © 2010, Flash Technology®, Franklin, TN, 37067, U.S.A.

All rights reserved. Reproduction or use of any portion of this manual is prohibited without express written permission from Flash Technology and/or its licensor.

### ***Trademark Acknowledgements***

Flash Technology® is a registered trademark name.

ElectroFlash™, Flash Tech™, Flash Technology™, FTCA™, Flash™ and the Flash Technology Logo are all trademarks of Flash Technology.

All trademarks and product names mentioned are properties of their respective companies and are recognized and acknowledged as such by Flash Technology.

### ***Disclaimer***

While every effort has been made to ensure that the information in this manual is complete, accurate and up-to-date, Flash Technology assumes no liability for damages resulting from any errors or omissions in this manual, or from the use of the information contained herein. Flash Technology reserves the right to revise this manual without obligation to notify any person or organization of the revision.

In no event will Flash Technology be liable for direct, indirect, special, incidental, or consequential damages arising out of the use of or the inability to use this manual.

### ***Warranty***

Flash Technology warrants all components, under normal operating conditions, for 5 years.

## **Personnel Hazard Warning**

### ***Dangerous Voltages***

Dangerous line voltages reside in certain locations in this equipment. Also, this equipment may generate dangerous voltages. Although Flash Technology has incorporated every practical safety precaution, exercise extreme caution at all times when you expose circuits and components, and when you operate, maintain, or service this equipment.

### ***Avoid Touching Live Circuits***

Avoid touching any component or any part of the circuitry while the equipment is operating. Do not change components or make adjustments inside the equipment with power on.

### ***Do Not Depend on Interlocks***

Never depend on interlocks alone to remove unsafe voltages. Always check circuits with a voltmeter after turning the circuit breakers off. Under no circumstances remove or alter the wiring or interlock switches.

# Table of Contents

FTB 360i-2 LED Integrated Beacon.....	i
Front Matter .....	ii
Abstract.....	ii
Copyright .....	ii
Trademark Acknowledgements .....	ii
Disclaimer .....	ii
Warranty .....	ii
Personnel Hazard Warning .....	iii
Dangerous Voltages.....	iii
Avoid Touching Live Circuits .....	iii
Do Not Depend on Interlocks .....	iii
Table of Contents.....	iv
List of Figures.....	v
List of Tables .....	v
Section 1 - Overview .....	1
Section 1.1 Beacon Component Identification .....	2
Section 2 – Installation – Mounting, Wiring, and Checkout .....	5
2.1 Mounting the Beacon.....	5
2.2 Wiring the Beacon .....	7
2.3 Verifying Operation.....	7
2.3.1 Power up .....	7
2.3.2 Synchronization Underway .....	8
2.3.3 Synchronization Complete.....	8
Section 3 - Operation .....	9
3.1 Indicators and Configuration .....	9
Section 4 - Beacon Theory of Operation .....	10
4.1 System Overview.....	10
Section 5 - Maintenance and Troubleshooting .....	12
5.1 Maintenance.....	12
5.2 Troubleshooting.....	13
5.3 Beacon Repair Procedures .....	14
5.3.1 Replacing the Controller Assembly (11000010471) .....	14
5.3.2 Replacing the Power Supply (11000010303).....	15
5.3.3 Replacing the Surge Suppressors (11000010290).....	15
5.3.4 Replacing the LED Module with Controller (11000010472).....	16
5.4 Customer Service.....	23
5.5 Ordering Parts.....	23
Section 6 – Specifications.....	24
Section 7 – Regulatory Compliance and Certifications.....	24
Return Material Authorization (RMA) Policy.....	25
Return to Stock Policy .....	25

## List of Figures

Figure 1-1 – Beacon - External View .....	2
Figure 1-2 – Beacon Exploded View.....	3
Figure 1-3 – Beacon Base Assembly.....	4
Figure 2-1 – Beacon - Bottom View.....	6
Figure 3-1 – Beacon Configuration and Indicators .....	9
Figure 4-1 – Beacon Wiring Diagram .....	11
Figure 5-1 – Beacon Locking Tab .....	17
Figure 5-2 – Remove Controller Assembly.....	17
Figure 5-3 – Wiring Harness Connector.....	18
Figure 5-4 – Remove Wires from Power Supply Connector.....	19
Figure 5-5 – Power Supply Output Connector .....	19
Figure 5-6 – Remove Surge Suppressor Assembly.....	20
Figure 5-7 – Replace Surge Suppressor.....	20
Figure 5-8 – Remove Wires from Terminal Block.....	21
Figure 5-9 – Remove LED Module .....	21
Figure 5-10 – Base Component Locations .....	22

## List of Tables

Table 2-1 – Power & Alarm Connections .....	7
Table 2-2 – Beacon and LED States – Day Mode.....	7
Table 2-3 – Beacon and LED States – Night Mode .....	7
Table 3-1 – Configuration Jumpers .....	9
Table 3-2 – Status LED’s .....	9
Table 3-3 – Alarm LED’s .....	9
Table 5-1 – Troubleshooting - Beacon is in Alarm .....	13
Table 5-2 – Troubleshooting - Beacon does not Flash at night.....	13
Table 5-3 – Troubleshooting - Beacon flashes but not in sync .....	13
Table 5-4 – Troubleshooting - Beacon flashes in daytime .....	13
Table 5-5 – Optional Parts .....	23
Table 5-6 – Spare/Replacement Parts.....	23



## **Section 1 - Overview**

The FTB 360i-2 LED Integrated L-864 Flashing Red Beacon as shown in Figure 1-1, (hereafter referred to as the beacon) is pre-wired with a power & alarm cable and operates from 120-240VAC 50/60 Hz. The only required customer connection is the AC line; as the beacon incorporates an integrated controller which flashes the beacon at night. The controller also has an integrated GPS receiver and antenna that allows synchronization to other beacons with no additional wiring. Alarm contacts are available for operation monitoring. The beacon consists of 36 high-performance LED's that provide the FAA required light output while consuming 95% less electrical power than an incandescent fixture.

The beacon is designed for the lighting of wind turbines, towers, flare stacks, chimneys, offshore oil platforms, petrochemical facilities and other obstructions to aerial navigation, as specified by the FAA, FCC, ICAO and Transport Canada.

This manual provides guidance and recommendations for the installation and checkout of the beacon assembly. Please read this document in its entirety before installing the beacon.

**Section 1.1 Beacon Component Identification**

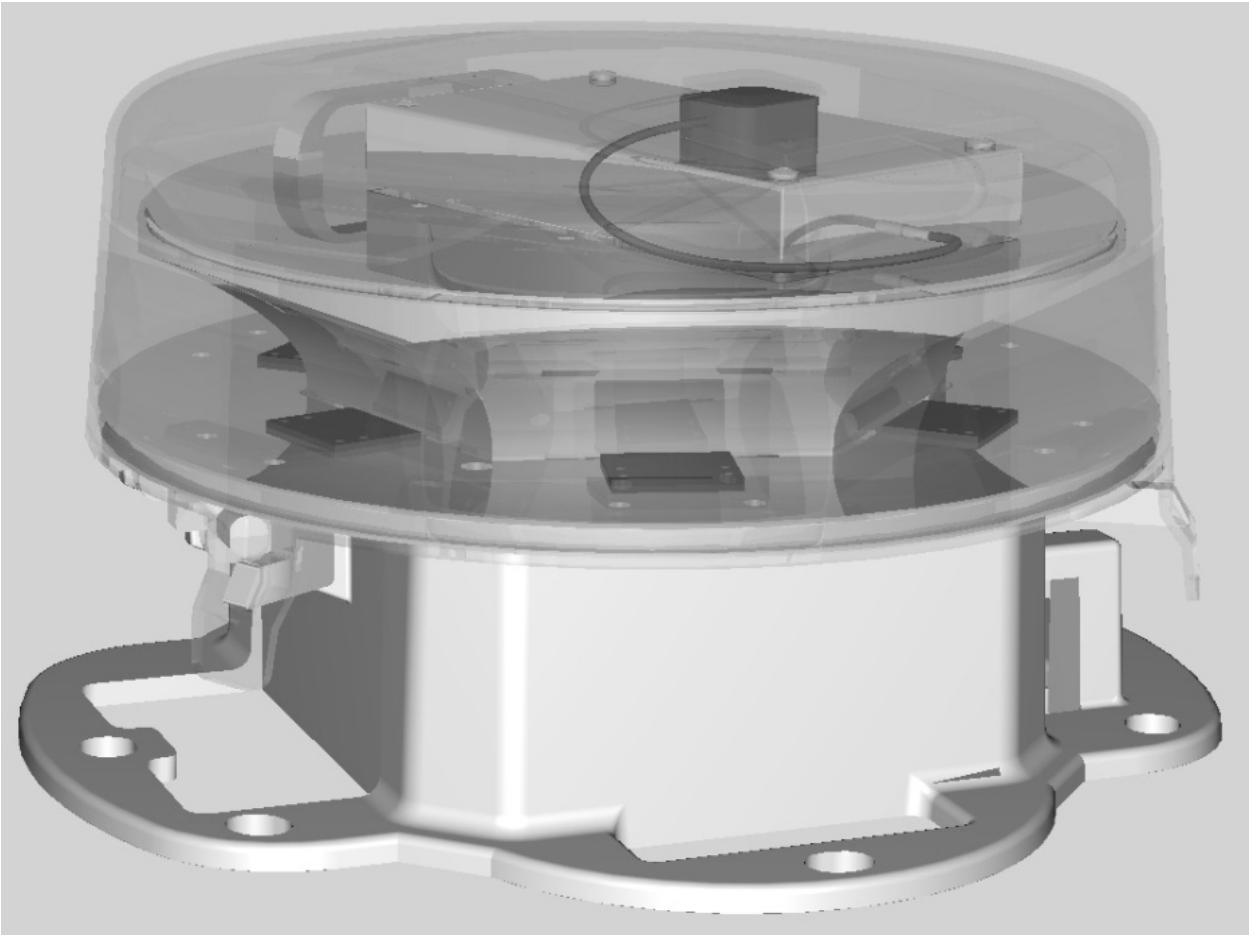

Figure 1-1 – Beacon - External View



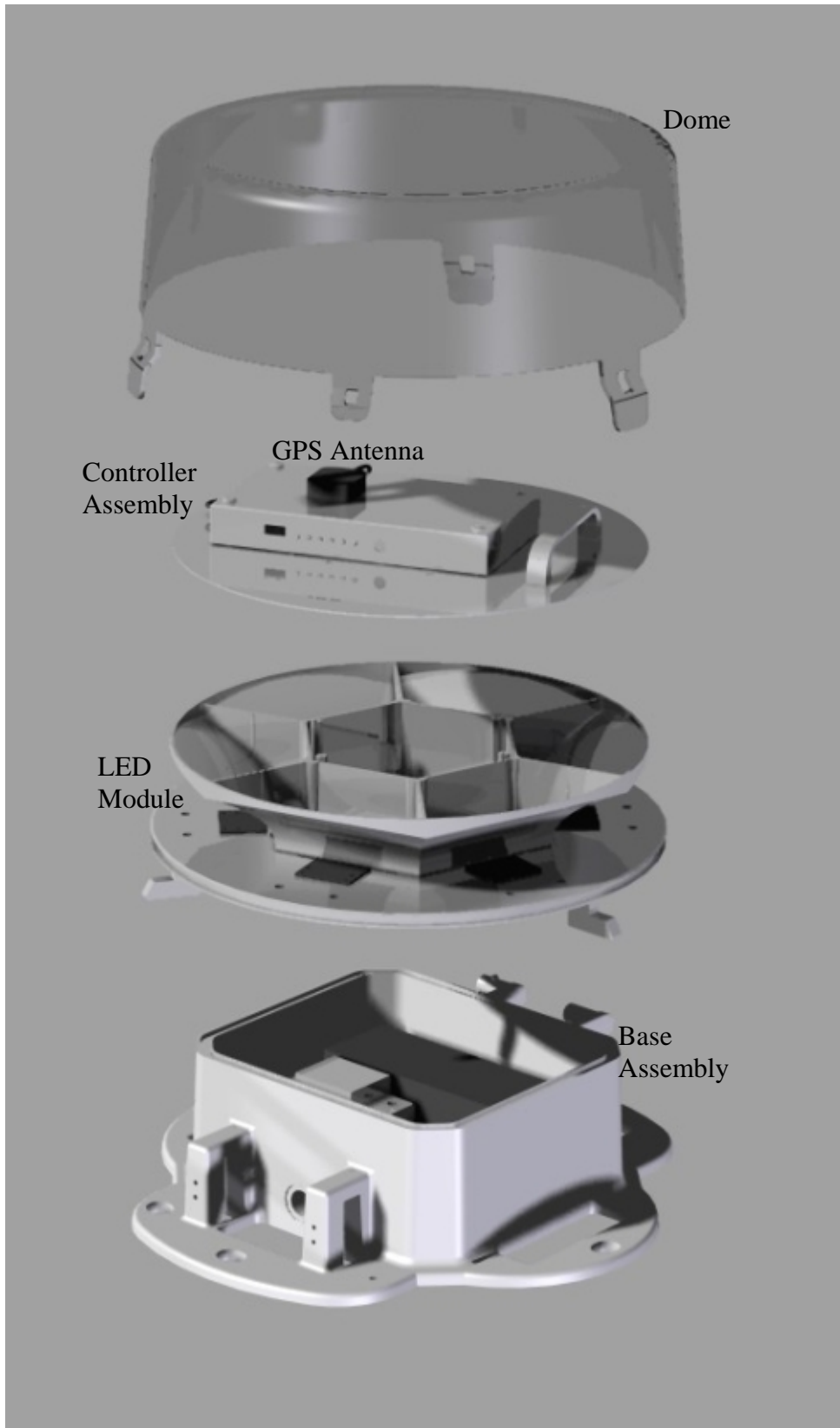

Figure 1-2 – Beacon Exploded View

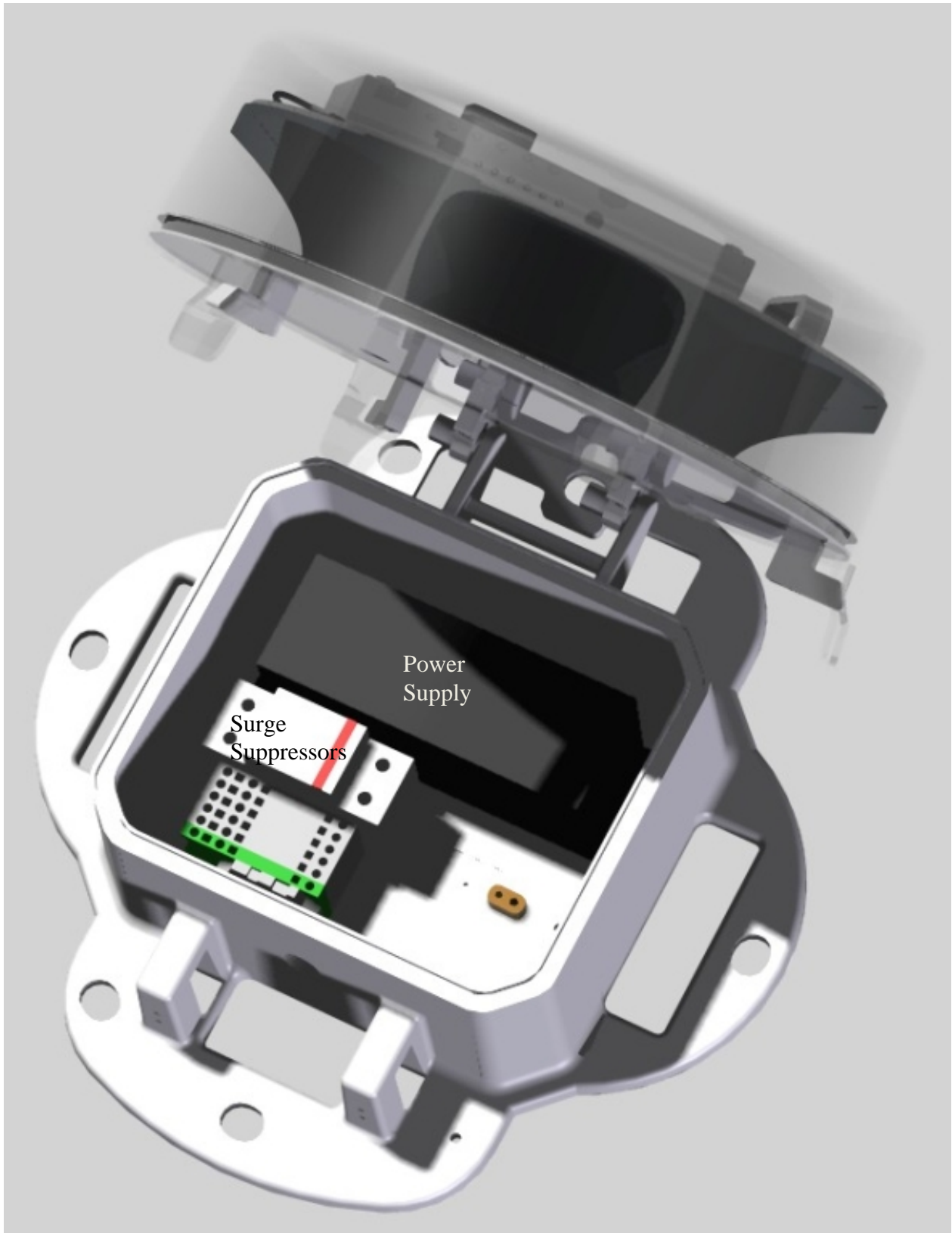

Figure 1-3 – Beacon Base Assembly

## Section 2 – Installation – Mounting, Wiring, and Checkout

### Warning

Read the warning on page iii now. Remove power from all wiring and circuitry before installing or performing work on the beacon. It is the responsibility of the installer to comply with all applicable electrical codes.

Ensure the base is electrically bonded to the site grounding system.

### Installation Procedure:

1. Mount the beacon (Section 2.1)
2. Wire the beacon power (Section 2.2)
3. Verify operation (Section 2.3)
4. Wire the beacon monitoring connections (Section 2.2)
5. Confirm monitoring status by disconnecting power to the beacon. This should create an alarm.

After all steps are completed successfully, the installation is complete.

### 2.1 Mounting the Beacon

Flash Technology recommends the installation of one or more lightning rods near the installed beacon. The lightning rods should extend a minimum of three feet above the height of the beacon.

The beacon should be positioned so that the photocell (Figure 3-1) points to the north and has an unobstructed view of the polar sky. Also, it must not view direct or reflected artificial light. The GPS antenna located on top of the beacon must have an unobstructed view of the sky for proper reception and synchronization.

The beacon is mounted to the tower pedestal or optional mounting bracket\* utilizing supplied hardware. Six mounting holes are provided on the beacon base (Figure 2-1). These mounting holes will align with most tower pedestals. The beacon should be installed level to maintain light output in accordance with FAA requirements.

\*An optional mounting bracket is available to accommodate various installation configurations and to facilitate leveling the beacon. See Section 5.5 for ordering information.

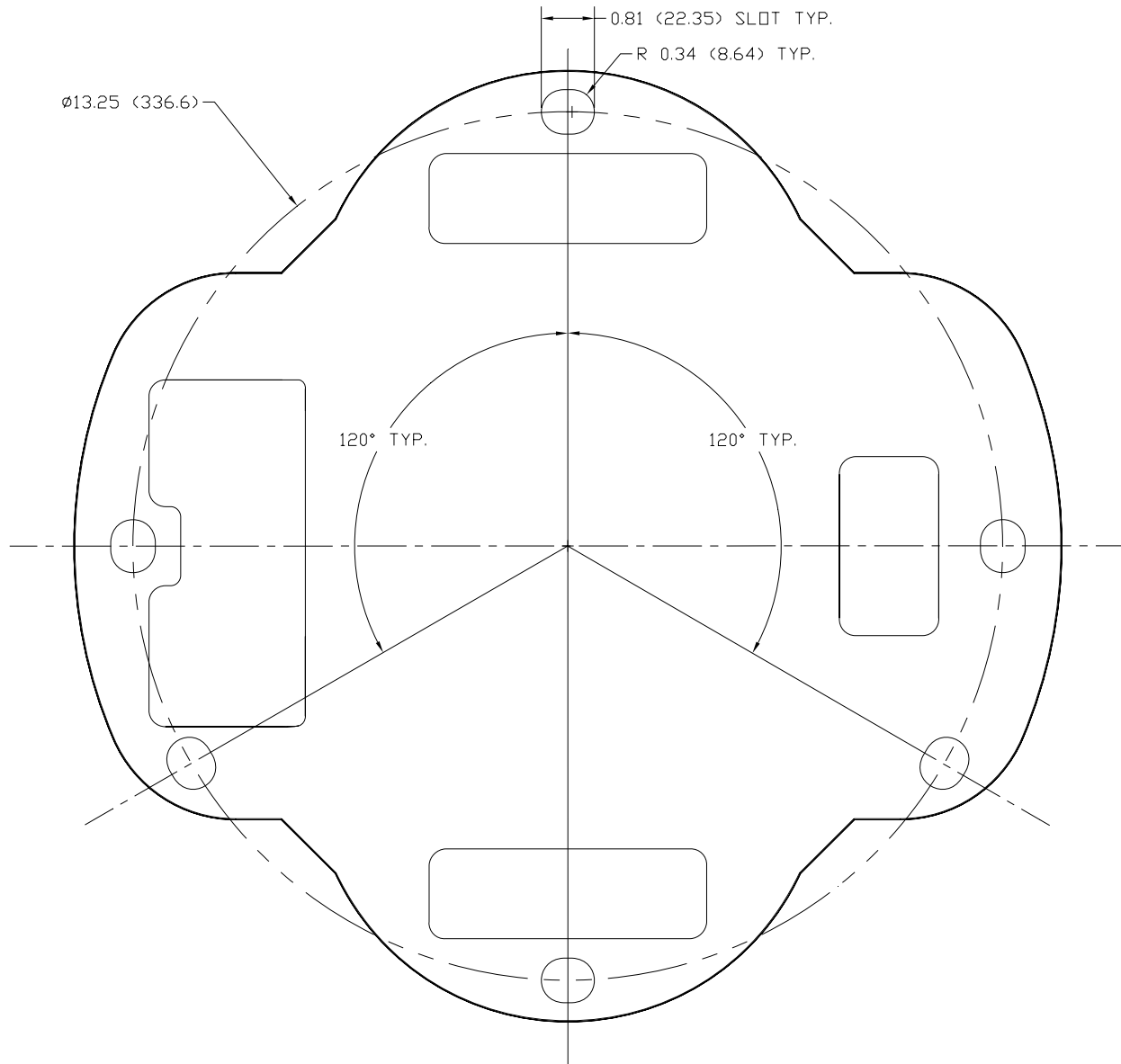

NOTE: ALL DIMENSIONS ARE IN INCHES (MILLIMETERS)

Figure 2-1 – Beacon - Bottom View

## 2.2 Wiring the Beacon

The beacon is supplied with a 50 foot power & alarm cable pre-wired to the internal electronics to facilitate installation. The only connection required is power (120-240 VAC, 50/60 Hz) and ground. The ground wire must be connected for proper operation and protection of the beacon. Optional dry contact monitoring connections permit monitoring of beacon operation. The contact is closed when the beacon is operating normally and no fault is detected.

**Table 2-1 – Power & Alarm Connections**

Terminal	Wire Color
Power – (120V: Line / 240V: L1)	Black
Power – (120V: Neutral / 240V: L2)	White
Power – Earth Ground	Green
Monitoring – Common	Red
Monitoring – Normally Closed	Orange

## 2.3 Verifying Operation

Apply power to the beacon and verify operation as indicated by the beacon and indicator LED's as shown in Table 2-2 and 2-3. More information on the LED indicators is provided in Section 3.1.

**Table 2-2 – Beacon and LED States – Day Mode**

	Beacon	Indicator LED's					
		STATUS			ALARM		
		PWR	MODE	SYNC	LED	PEC	SYNC
1. Power Up (10 seconds)	ON	ON	ON	ON	ON	ON	ON
2. Synchronization underway	OFF	ON	OFF	OFF	OFF	OFF	OFF
3. Synchronization complete	OFF	ON	OFF	ON	OFF	OFF	OFF

**Table 2-3 – Beacon and LED States – Night Mode**

	Beacon	Indicator LED's					
		STATUS			ALARM		
		PWR	MODE	SYNC	LED	PEC	SYNC
1. Power Up (2 seconds)	ON	ON	ON	ON	ON	ON	ON
2. Synchronization underway	FLASH	ON	FLASH	OFF	OFF	OFF	OFF
3. Synchronization complete	FLASH	ON	FLASH	ON	OFF	OFF	OFF

### 2.3.1 Power up

If powered up during the Day (photocell detects sufficient light), the beacon and all indicator LED's are turned on for 10 seconds, providing easy verification of operation during install. Verify that the beacon is on during this time.

If powered up at Night, the beacon and LED's are initially turned on for only 2 seconds.

### **2.3.2 Synchronization Underway**

Following power up in daytime, the beacon should be off. At nighttime, the beacon and the MODE status LED flash at a rate of 20 flashes per minute. The PWR status LED should be on and all alarm LED's should be off.

After power up or power loss, as much as 15 minutes may be required for synchronization. Synchronization is not complete while the SYNC status LED is off. For synchronization to occur, the GPS antenna located on top of the beacon must have an unobstructed view of the sky.

### **2.3.3 Synchronization Complete**

When synchronization is complete, the SYNC status LED will be on solid. This is the normal operating condition.

## Section 3 - Operation

### 3.1 Indicators and Configuration

Located on top of the beacon are configuration jumpers, LED indicators, and the photocell. A description of each is provided below. See Section 2.3 for more information on the Status LED's.

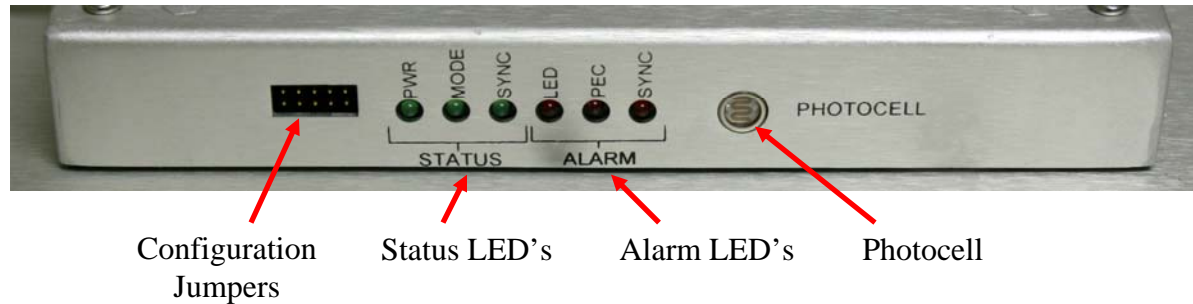

Figure 3-1 – Beacon Configuration and Indicators

**Table 3-1 – Configuration Jumpers**

To configure a particular option, move the spare jumper shunt to the specified location. See the Dome Removal and Dome Reassembly procedures in Section 5.

PEC DEFEAT	DELAY	NOT USED	MANUAL DAY	MANUAL NIGHT
Disables photocell alarm	Provides Sync with Orga L350-864-G <sup>1</sup>	Holds spare jumper shunt	Forces day operation	Forces night operation

(1) Flash Technology will NOT be responsible for any changes to GPS sync response by other manufacturers.

**Table 3-2 – Status LED's**

Name	Function
PWR	On indicates the beacon is powered.
MODE	Flashes on corresponding to the beacon flash; off during the day.
SYNC	On indicates proper GPS synchronization. After power up, 15 minutes may be required for synchronization.

**Table 3-3 – Alarm LED's**

Name	Function
LED	On indicates insufficient or no current drawn by the beacon LED power supply and LED module when flashed.
PEC	On indicates no transition between day and night sensed by the photocell for an extended period (Day > 19 hours, Night > 5 days)
SYNC	On indicates flashing of the beacon is not synchronized.

#### PHOTOCELL

The Photocell senses day and night light levels for beacon mode control per FAA guidelines.

## **Section 4 - Beacon Theory of Operation**

### **4.1 System Overview**

The beacon wiring diagram is shown in Figure 4-1.

The customer connection power & alarm cable provides connection of the AC line (3 wires) and alarm monitoring connections (2 wires). The AC line may be 120-240VAC 50/60Hz. The dry contact alarm connections are closed when the beacon is operating normally and no fault is detected.

The Controller Assembly (11000010471) senses ambient light with a photocell and at night flashes the LED beacon by connecting AC line voltage to the LED power supply. A GPS antenna and integrated receiver permit synchronization to other beacons. The controller detects alarm conditions including beacon failure, photocell alarm, and synchronization fault. Status and alarm LED's are provided to permit easy determination of proper operation and fault diagnosis.

The LED module contains the 36 high-performance LED's which illuminate when powered by the LED power supply. The LED Module (11000010472), complete with dome and controller, is easily replaced when field service is required.

The LED Power Supply (11000010303) and the Surge Suppressors (11000010290) are located in the base of the beacon. The LED power supply generates the proper DC current to the LED module when AC line voltage is applied at its input. The surge suppressors, wired in line with and directly across the AC Line, provide protection from incoming lightning and transient voltage induced surges.



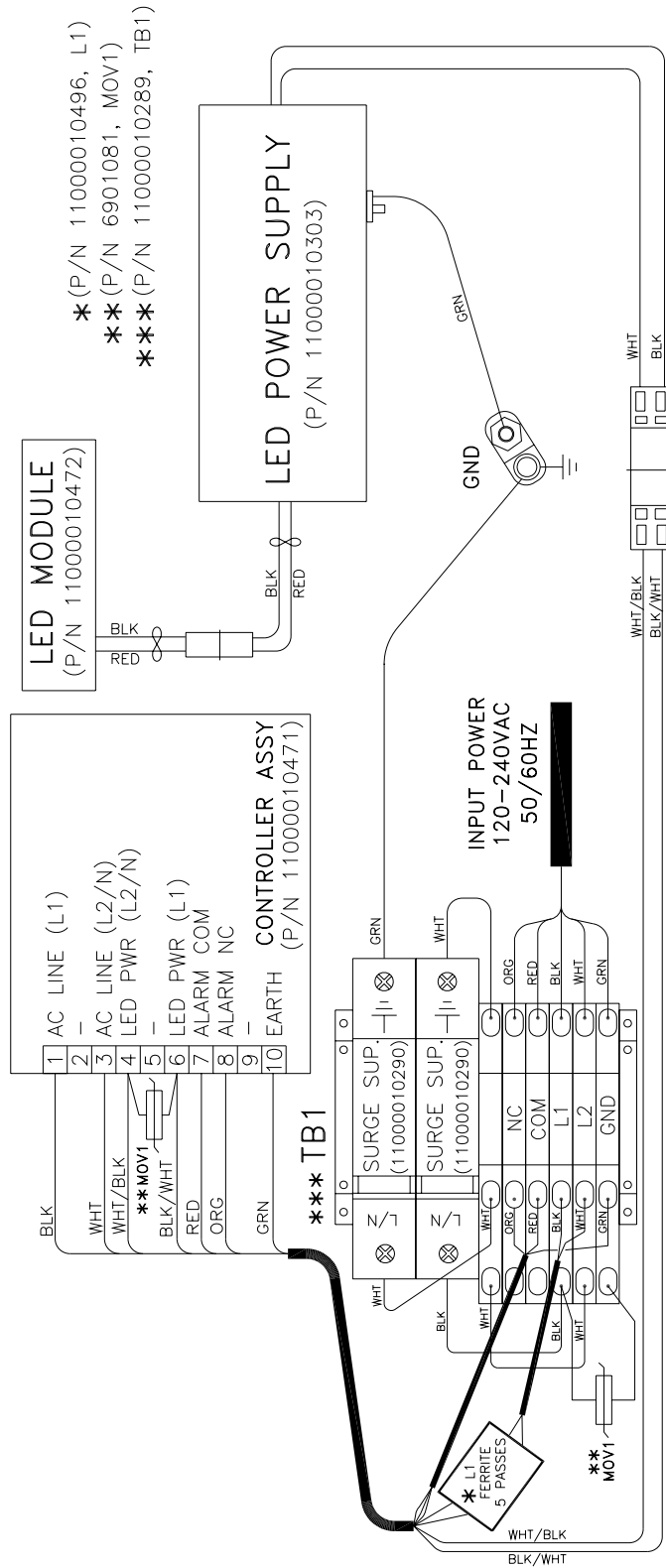

Figure 4-1 – Beacon Wiring Diagram

## **Section 5 - Maintenance and Troubleshooting**

### **5.1 Maintenance**

No regularly scheduled maintenance is required for the beacon.

- Flash Technology warranties the light output of the beacon to meet or exceed FAA requirements for a 5 year period. LED module replacement after 5 years is recommended to insure FAA compliance. See Section 5.3.3.
- Periodic cleaning of the dome is recommended with regular glass cleaning solution, soapy water or any acrylic cleaning solutions. No other cleaning solutions are recommended. Abrasive compounds will scratch the dome.
- Optional mounting brackets should be checked periodically for tightness.

## 5.2 Troubleshooting

Follow the troubleshooting steps in the tables below as applicable. Beacon repair procedures are provided in Section 5.3

**Table 5-1 – Troubleshooting - Beacon is in Alarm**

Step	Check/Test/Action		Action
1.a	Is beacon flashing at night?	Yes No	Go to Step 1.b Go to Step 2.a
1.b	Is beacon flashing in sync with other FTB 360i-2 beacons? Check beacon <u>SYNC</u> Status and <u>SYNC</u> Alarm LED's.	Yes No	Go to Step 1.c Go to Step 3
1.c	Is beacon <u>PEC</u> Alarm LED on? Does beacon flash in daytime?	Yes No	Go to Step 4

**Table 5-2 – Troubleshooting - Beacon does not Flash at night**

Step	Check/Test/Action		Action
2.a	Is AC power applied? Measure at beacon terminals (Section 2.1)	Yes No	Go to Step 2.b Correct problem.
2.b	Is the photocell positioned correctly? Check installation (Section 2.2)	Yes No	Go to Step 2.c Correct problem.
2.c	Is beacon <u>PWR</u> Status LED on?	Yes No	Go to Step 2.d Replace controller assembly (See Section 5.3.1)
2.d	Is beacon <u>MODE</u> Status LED flashing?	Yes No	Go to Step 2.e Replace controller assembly (See Section 5.3.1)
2.e	Is beacon <u>LED</u> Alarm LED on?	Yes No	Replace beacon power supply assembly (See Section 5.3.2) Replace controller assembly (See Section 5.3.1)

**Table 5-3 – Troubleshooting - Beacon flashes but not in sync**

Step	Check/Test/Action		Action
3	Does GPS antenna (located in top of beacon) have an unobstructed view of sky? See Section 2.2	Yes No	Replace controller assembly See Section 5.3.1 Correct problem

**Table 5-4 – Troubleshooting - Beacon flashes in daytime**

Step	Check/Test/Action		Action
4	Is photocell (located on top of beacon) obstructed? Check for any foreign matter on top of beacon.	Yes No	Correct problem Replace controller assembly See Section 5.3.1

## **5.3 Beacon Repair Procedures**

### **Warning**

Read the warning on page iii now. Remove power from all wiring and circuitry before installing or performing work on the beacon. It is the responsibility of the installer to comply with all applicable electrical codes.

### **5.3.1 Replacing the Controller Assembly (11000010471)**

While performing the following steps, check for any loose connections or other damaged components.

#### **Dome Removal**

The Dome (11000010306) is secured to the beacon base by three pins (Figure 5-1). Gently pull out and up on the base of the tab to clear the *locking pin*. The dome lanyard is secured to the beacon base support bolt. Once the tabs are clear, the dome may be carefully lifted off the top of the beacon by gently pulling upward. Set the dome aside until ready for re-installation.

#### **Controller Assembly Removal**

Remove the four panhead screws (Figure 5-2) securing the controller assembly (11000010471) to the top plate. Lift the controller assembly slightly then unplug the wiring harness connector from the controller PCB (Figure 5-3).

#### **Controller Assembly Replacement**

Plug the main harness connector into the replacement controller assembly. Rotate the controller assembly as necessary to position the LED module and lower into position. Reinstall using the four retaining screws.

#### **Operation Verification**

Apply power to the beacon and verify that it operates correctly. If not, recheck all connections. If the beacon functions normally, perform the Dome Reassembly procedure provided below.

#### **Dome Reassembly**

Refit the dome making sure that the O-ring is in place to insure a proper seal and prevent water intrusion. **CAUTION:** When reinstalling the dome it is important to hold it level and securely by the top outer edge. Make sure that the three locking tabs are lined up with the locking pins. With even pressure gently lower the dome over the o-ring seal until the tabs latch on the locking pins. Push in on each of the tabs to ensure that it is securely locked in place.

### **5.3.2 Replacing the Power Supply (11000010303)**

#### **Power Supply Removal**

Unfasten the two latches on the front of the base assembly. Lift the LED module to expose the power supply. Remove the black and white wires from the input power connector to the power supply (Figure 5-4). Disconnect the two position connector (black and red wires) on the output of the power supply (Figure 5-5). Remove the screw attaching the ground wire to the top of the power supply. Remove the four screws that attach the power supply to the base.

#### **Power Supply Reinstall**

Place the power supply in the base with the black and white wires nearest the ground lug. Mount the power supply to the base with four screws. Remove the screw on the top corner of the power supply nearest the ground lug and attach the ground wire. Insert a small screwdriver into the end of the power supply input power connector and reconnect the black and white wires. Reconnect the power supply output connector (black and red wires). Lower the LED module to the closed position and secure both latches on the base assembly. Apply power to the beacon and verify that it operates correctly. If not, recheck all connections.

### **5.3.3 Replacing the Surge Suppressors (11000010290)**

#### **Surge Suppressor Assembly Removal**

Unfasten the two latches on the front of the base assembly. Lift the LED module to expose the surge suppressors. Disconnect the wires at the L/N and the Ground positions. Insert a flat blade screwdriver into the slot below the Ground position and push the handle toward the terminal block to release the surge suppressor assembly (Figure 5-6). To replace only the surge suppressor, pull up on the surge suppressor module to remove it from the holder (Figure 5-7).

#### **Surge Suppressor Reinstall**

Position the L/N end of the surge suppressor over the DIN rail first. Insert a flat blade screwdriver into the slot below the Ground position and push the handle toward the terminal block. Push down on the surge suppressor assembly and remove the screwdriver. Verify that the surge suppressor is firmly attached to the DIN rail. Reconnect the wires to the surge suppressor. Lower the LED module to the closed position and secure both latches on the base assembly. Apply power to the beacon and verify that it operates correctly. If not, recheck all connections.

### **5.3.4 Replacing the LED Module with Controller (11000010472)**

#### **Disconnect Wiring Harness**

Unfasten the two latches on the front of the base assembly. Lift the LED module to expose the power supply. Remove the orange, red, black, white and green wires from the terminal block (Figure 5-8). Disconnect the two position connector (black/white and white/black wires) from the power supply input power connector. Disconnect the two position connector (black and red wires) on the output of the power supply (Figure 5-5).

#### **LED Module Removal**

From the closed position, raise the LED module to approximately 10° and slide the entire LED module off the hinge pins (Figure 5-9).

#### **LED Module Replacement**

Position the hinge on the LED module in line with the hinge pins on the base. Raise the LED module to approximately 10° and slide the entire LED module onto the hinge pins.

#### **Reconnect Wiring Harness**

Lift the LED module to expose the power supply. Connect the orange, red, black, white and green wires to the terminal block. Reconnect the two position connector (black/white and white/black wires) to the power supply input power connector. Reconnect the two position connector (black and red wires) to the output of the power supply.

#### **Operation Verification**

Lower the LED module to the closed position and secure both latches on the front of the base assembly. Apply power to the beacon and verify that it lights correctly. If not, recheck all connections.

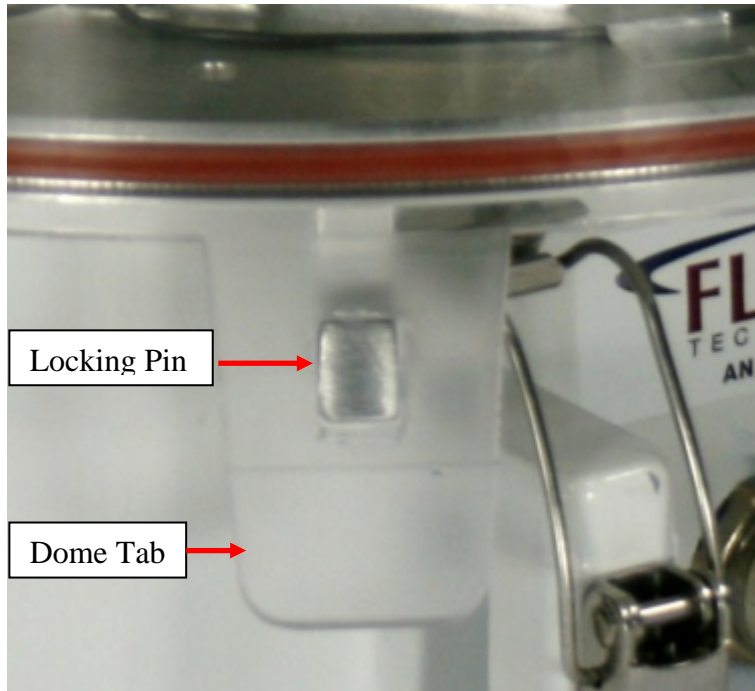

Figure 5-1 – Beacon Locking Tab

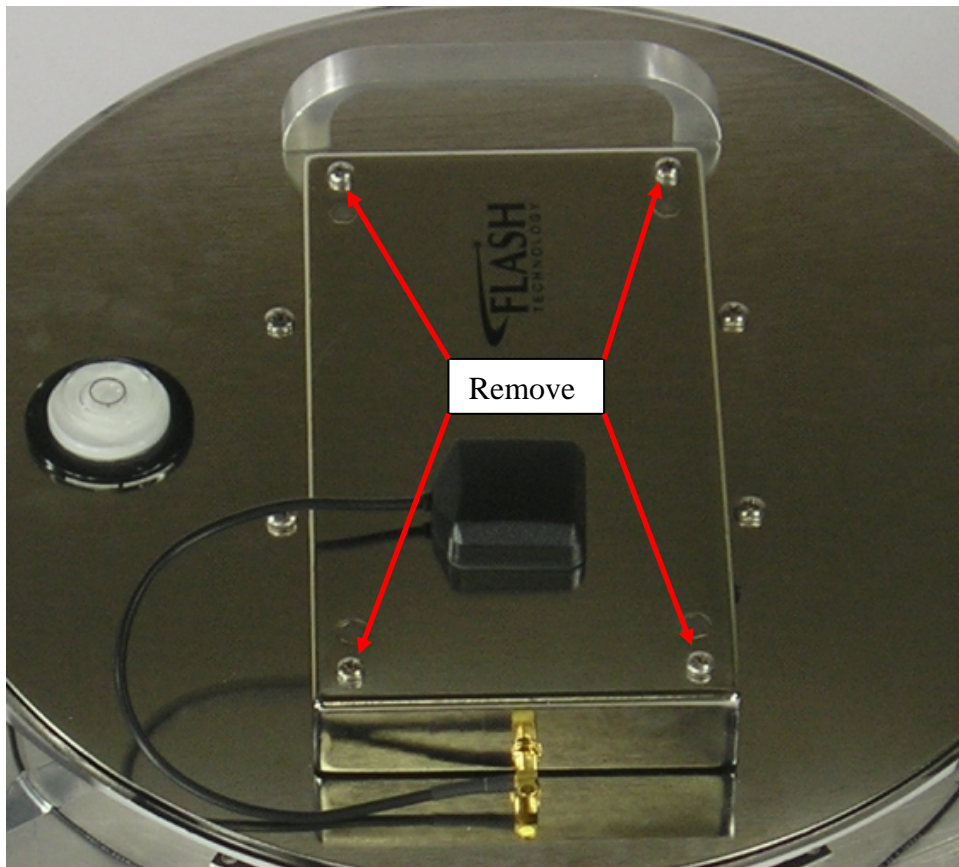

Figure 5-2 – Remove Controller Assembly

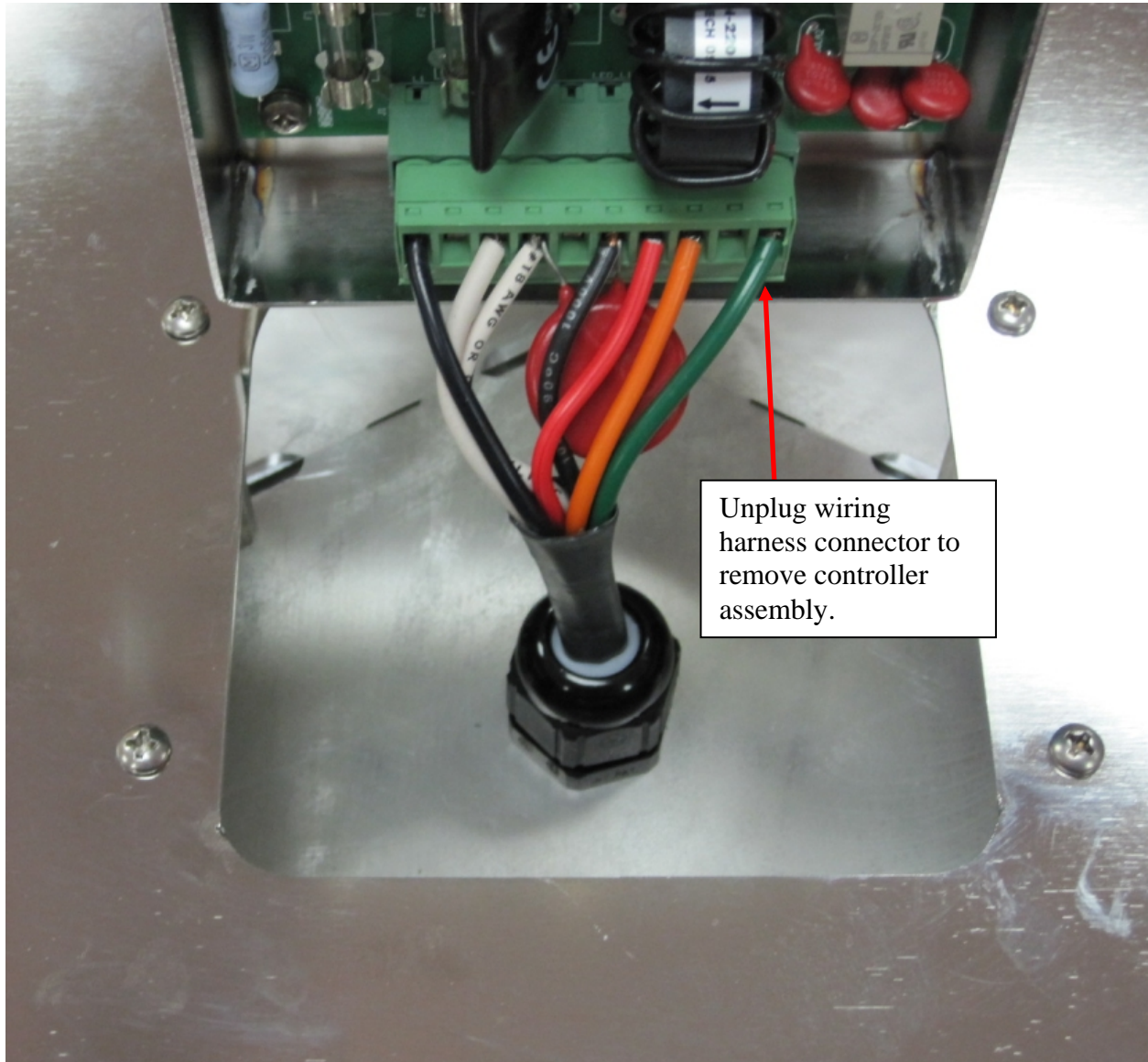

Figure 5-3 – Wiring Harness Connector



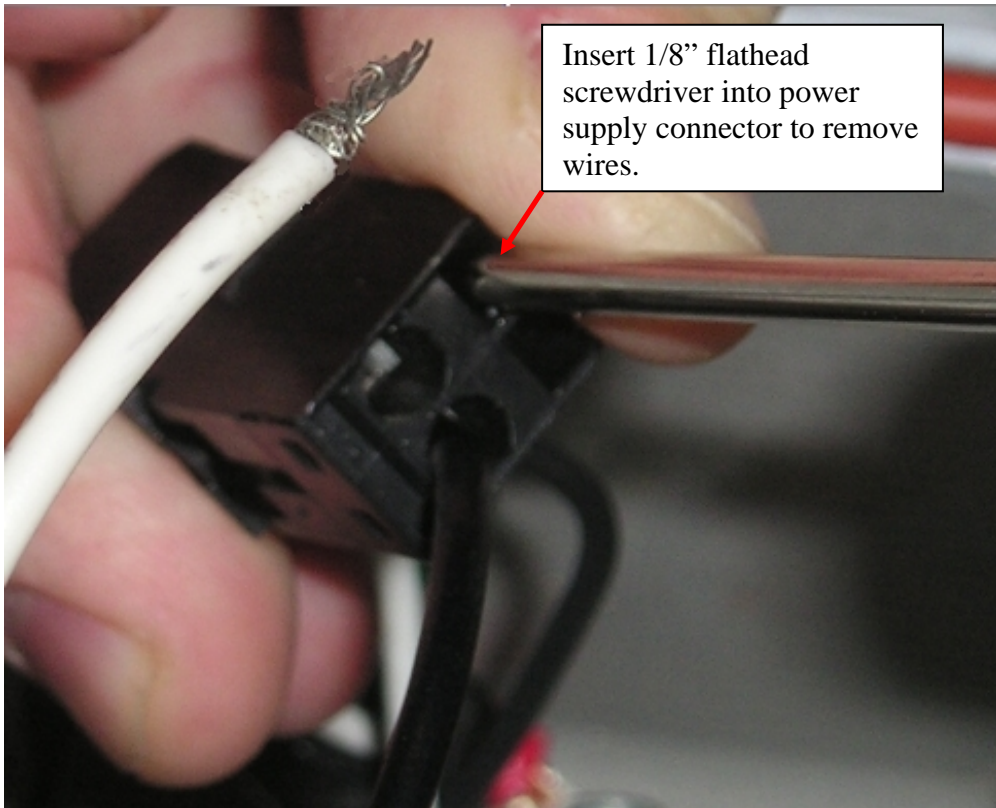

Figure 5-4 – Remove Wires from Power Supply Connector

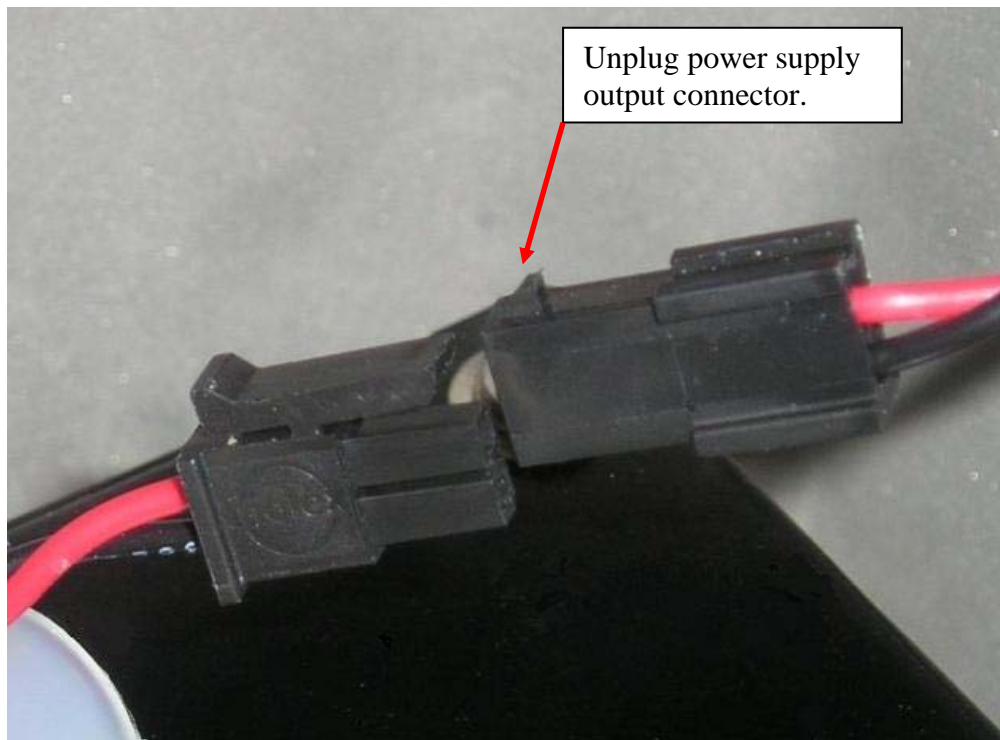

Figure 5-5 – Power Supply Output Connector



Figure 5-6 – Remove Surge Suppressor Assembly.

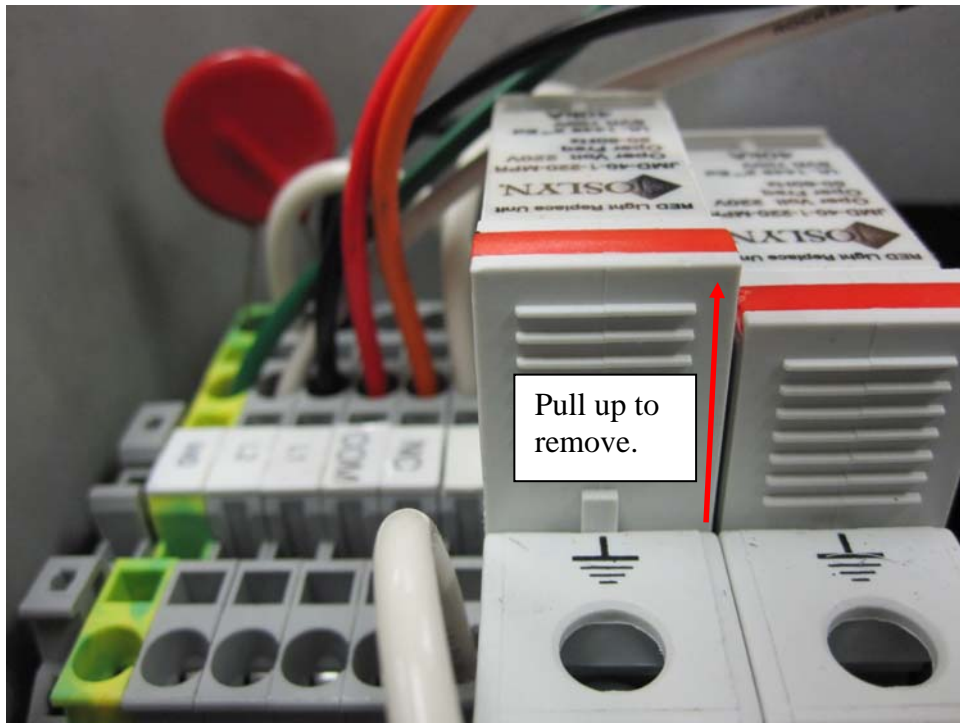

Figure 5-7 – Replace Surge Suppressor

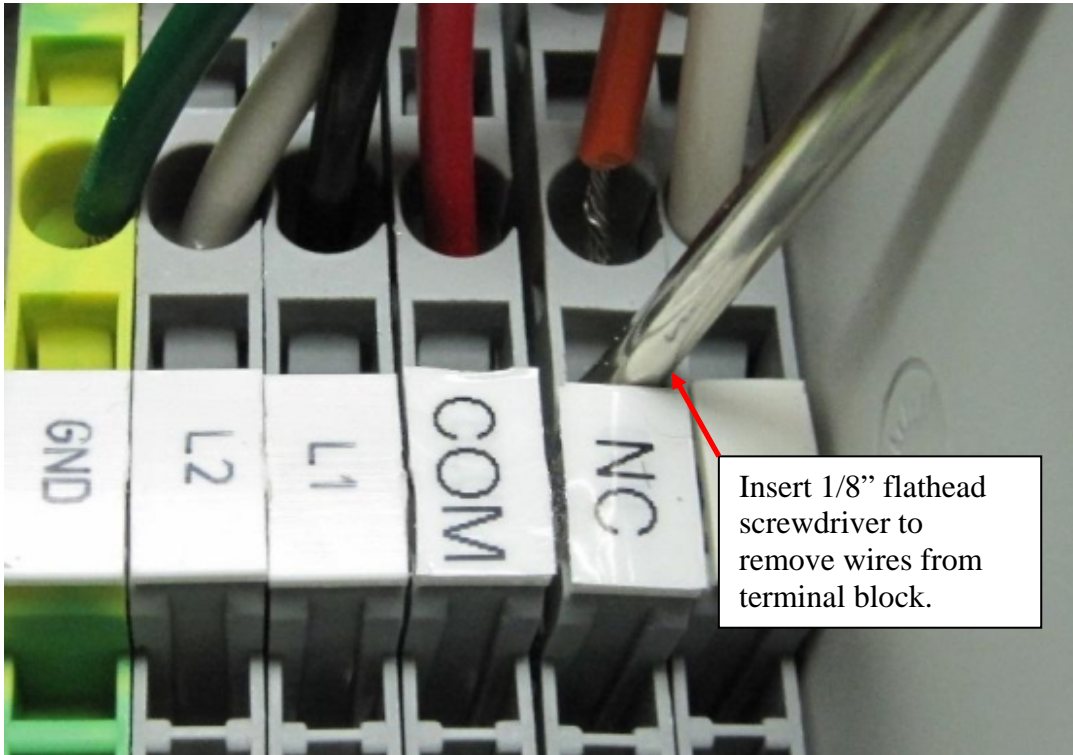

Figure 5-8 – Remove Wires from Terminal Block

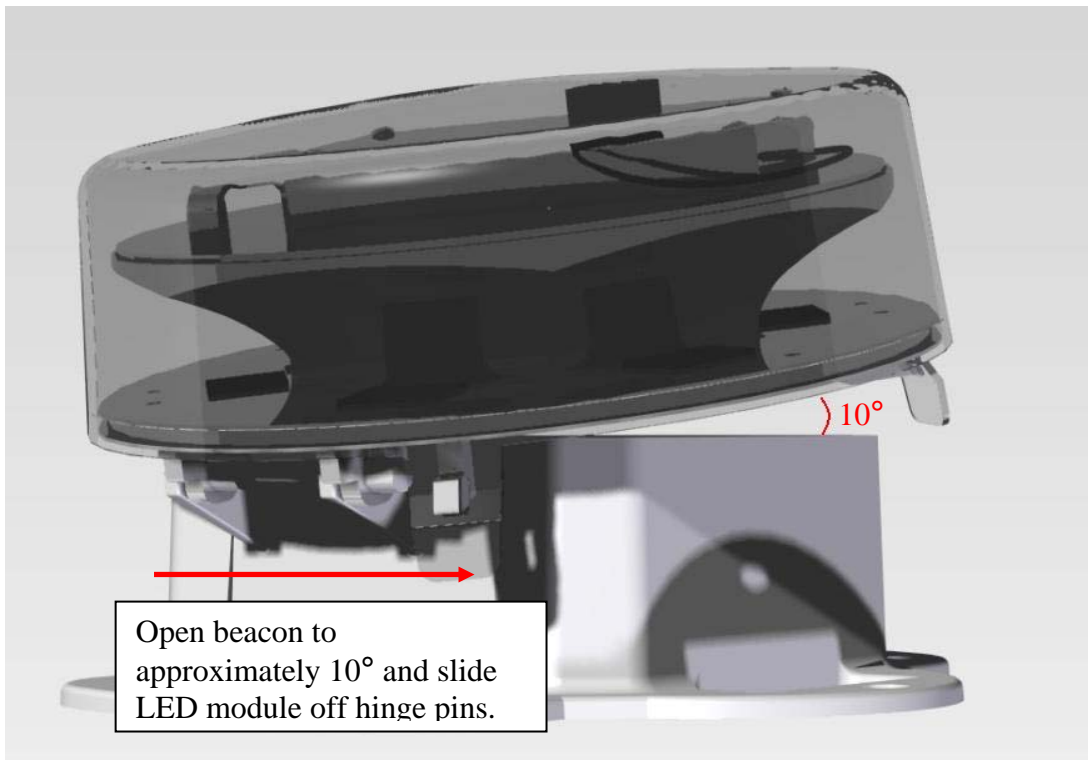

Figure 5-9 – Remove LED Module

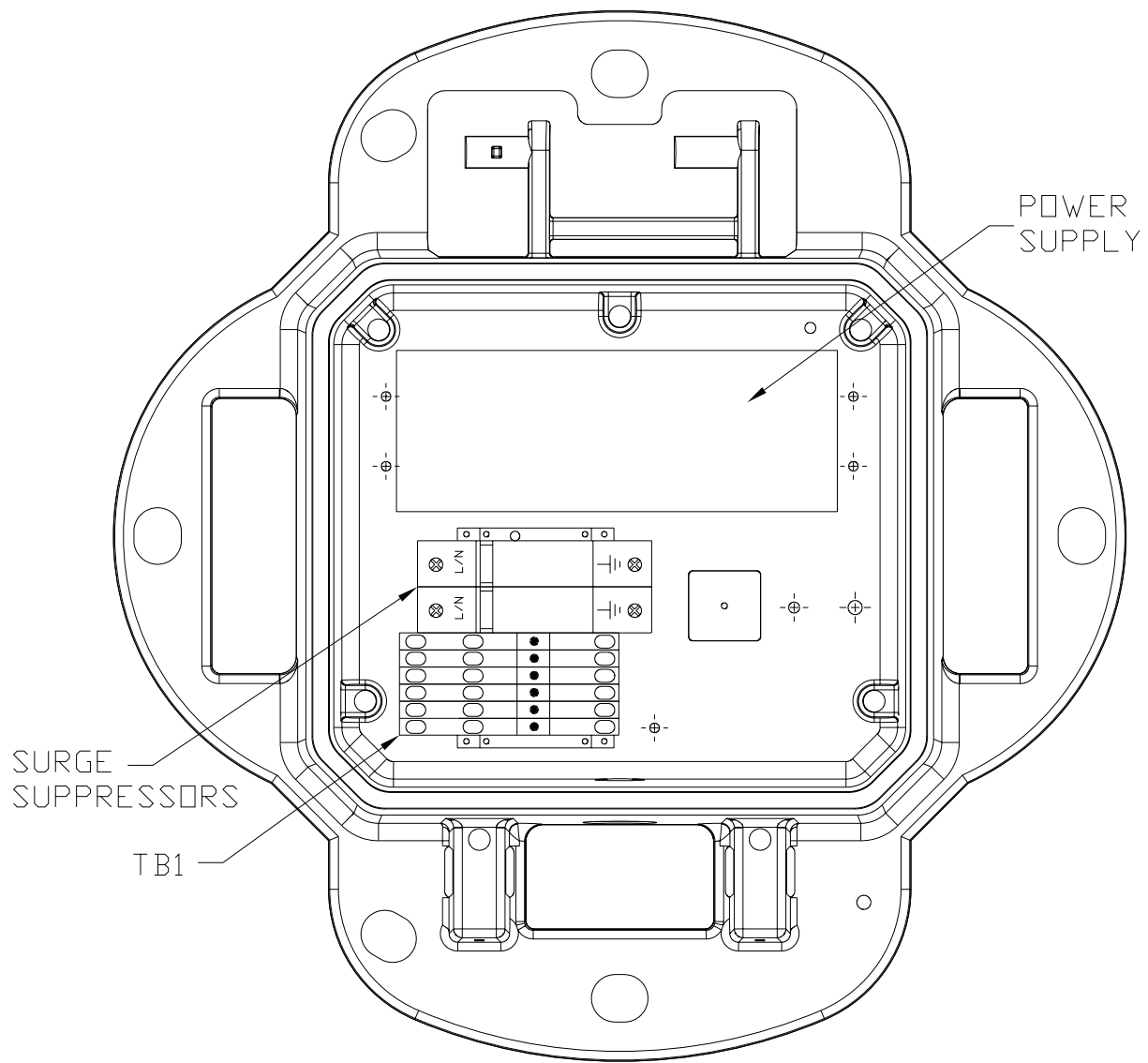

Figure 5-10 – Base Component Locations

## 5.4 Customer Service

Customer Service: (800) 821-5825

Telephone: (615) 261-2000

Facsimile: (615) 261-2600

Shipping Address:

Flash Technology  
332 Nichol Mill Lane  
Franklin, TN 37067

## 5.5 Ordering Parts

To order spare, replacement or optional parts contact Customer Service at 1-800-821-5825.

**Table 5-5 – Optional Parts**

<b>Description</b>	<b>Part Number</b>
Mounting Bracket Assembly Universal	3991210
Mounting Bracket Assembly (GE)	3991220
Mounting Bracket Assembly Standard	3991240

**Table 5-6 – Spare/Replacement Parts**

<b>Description</b>	<b>Part Number</b>
LED Module (with controller)	11000010472
Dome	11000010306
Controller Assembly	11000010471
Surge Suppressor Assembly 220V 40kVA (2 required)	11000010290
Power Supply	11000010303
Wiring Harness	11000010288
Terminal Block Assembly (TB1)	11000010289
Ferrite (L1)	11000010496
Varistor 230/240V Metal Oxide (MOV1)	6901081

## Section 6 – Specifications

FAA Type	L-864 Red Obstruction Light
Flashes per Minute	20 FPM
Intensity	2,000 candela (nominal)
Input Voltage Range	120-240VAC
Input Current	0.5 to 1.0A RMS
Frequency	50/60Hz
Wattage	25W (steady)
Power Factor	>0.9
Operating Temperature	-40°F to +131°F (-40°C to +55°C)
Weight	
Beacon only	22 lbs (10 kg)
Cable, 50 Feet (15.2 m)	6 lbs (2.7 kg)
Beacon w/ 50 Feet (15.2 m) cable	28 lbs (12.7 kg)
Dimensions	
Height	8.4 in (213.4 mm)
Width	15.0 in (381 mm)
Bolt Hold Down Pattern	Standard Pattern Provided (See Figure 2-1)

## Section 7 – Regulatory Compliance and Certifications

- ETL Certified to Federal Aviation Administration (FAA): AC No. (150/5345-43F).
- FAA Engineering Brief No. 67
- Compliant to Canadian Aviation Regulation (CAR): CAR 621.19
- International Civil Aviation Organization (ICAO): Annex 14, 4<sup>th</sup> Edition, July 2004

# Return Material Authorization (RMA) Policy

IF A PRODUCT PURCHASED FROM FLASH TECHNOLOGY MUST BE RETURNED FOR ANY REASON (SUBJECT TO THE WARRANTY POLICY), PLEASE FOLLOW THE PROCEDURE BELOW:

**Note:** An RMA number must be requested from Flash Technology prior to shipment of any product. No returned product will be processed without an RMA number. This number will be the only reference necessary for returning and getting information on the product's progress.

**Failure to follow the below procedure may result in additional charges and delays. Avoid unnecessary screening and evaluation charges by contacting Technical Support prior to returning material.**

**1. To initiate an RMA, customers should call Flash Technology's Network Operation Center at (800-821-5825) to receive technical assistance and a Service Notification number. The following information is required before a Service Notification number can be generated:**

- Site Name/Number / FCC Registration number/ Call Letters or Airport Designator
- Site Owner (provide all that apply – owner, agent or subcontractor)
  - Contractor Name
  - Contractor Company
- Point of Contact Information: Name, Phone Number, Email Address, Fax Number and Cell Phone (or alternate phone number)
- Product's Serial Number
- Product's Model Number or part number
- Service Notification Number (if previously given)
- Reason for call, with a full description of the reported issue

**2. The Service Notification number will then serve as a precursor to receiving an RMA number if it is determined that the product or equipment should be returned. To expedite the RMA process please provide:**

- Return shipping method
- Purchase Order (if non-warranty repair)
- Shipping Address
- Bill To Address
- Any additional information to assist in resolving the issue or problem

**3. A P.O. is required in advance for the replacement of product that may be under warranty. Flash will then, at its discretion issue a credit once the validity of the warranty has been determined.**

**4. A purchase order (P.O.) is also required in advance for all non-warranty repairs. NOTE: the purchase order is required prior to the issuance of the RMA number.**

- If the P.O. number is available at the time of the call, an RMA number will be issued and the customer must then fax or email the P.O. with the RMA number as the reference, to ensure prompt processing.
- If the P.O. number is NOT available at the time of the call, a Service Notification Number will be given to the customer and should be referenced on the P.O. when faxed or emailed to RMA Rep.
- Flash will then, at its discretion repair or replace the defective product and return the product to the customer based on the shipping method selected.
- The customer may purchase a new product before sending in the existing product for repair. If Flash Technology determines the existing product is still covered under warranty a credit will be issued to the customer for the new product.

**5. After receiving the Flash Technology RMA number, please adhere to the following packaging guidelines:**

- All returned products should be packaged in a way to prevent damage in transit. Adequate packing should be provided taking into account the method of shipment.

**Note: Flash Technology will not be responsible for damaged items if product is not returned in appropriate packaging.**

**6. All packages should clearly display the RMA number on the outside of all RMA shipping containers. RMA products (exact items and quantity) should be returned to:**

Flash Technology  
Attn: RMA #XXX  
332 Nichol Mill Lane  
Franklin, TN 37067

**7. All RMA numbers:**

- Are valid for 30 days. Products received after may result in extra screening and delays.
- Must have all required information provided before an RMA number is assigned.

## Return to Stock Policy

- Parts can be returned within 60 days of ship date and will be subject to a 25% restocking fee. Product must:
  - Be in the original packaging
  - Not be damaged
- **After 60 days no parts can be returned**