

➤ Flash Technology







FTS 361X-4

**Red LED Obstruction Lighting System
Reference Manual
Part Number F7913614**

SERIAL NUMBER

Flash Technology, 332 Nichol Mill Lane, Franklin, TN 37067
(615) 261-2000

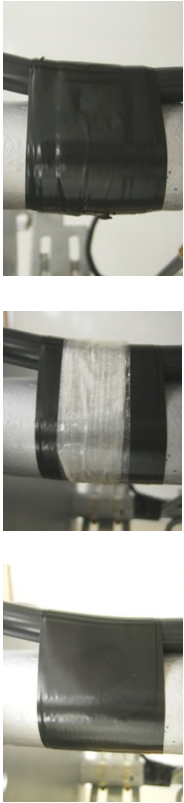
<p>1.</p> <p style="text-align: center;">ITEMS INCLUDED IN THIS SYSTEM</p> <ul style="list-style-type: none"> • Quick Start Guide/Manual • Controller • Beacon(s) & mounting hardware • Cable Installation Tape • PEC w/pigtail <p style="text-align: center;">RECOMMENDED ITEMS FOR INSTALLATION</p> <ul style="list-style-type: none"> • 9" or 12" #2 flathead screwdriver • Level • Long-nose pliers • Nut drivers: 1/4", 5/16", 3/8" • Combination wrenches to include 3/4" • 1/8" Flathead screwdriver • Marker kit with Flash brand tray cable, no conduit required • Optional: Universal adapter plate & hardware • Digital volt-ohm meter • Wire strippers • #2 Phillips® head screwdriver • Optional: 1/2" & 3/4" flex conduit & connectors 	<p>2.</p> <p style="text-align: center;">GENERAL INSTALLATION NOTES</p> <ul style="list-style-type: none"> • Photocell referred to as PEC, uppermost flashhead referred to as AOL • Controller operates from a universal input power (120 or 240VAC 50/60Hz) without configuration. • (1) 15 Amp circuit breaker is recommended for a typical system installation. • Controller should be grounded with #2 Copper into the site grounding system utilizing the preinstalled grounding lug inside the enclosure. • Incoming power connection, L2 on terminal block can also be Neutral. • Refer to pages a & a for installation checklist and punch-down. • Flash Technical support available 800-821-5825 M-F, 7am – 7pm CST. Monitoring support available 24/7/365. • It is the installer's responsibility to comply with all electrical codes and the guidelines outlined in the FAA Advisory Circulars.
<p>3.</p> <p style="text-align: center;">COMPONENT CONNECTIONS</p> <ul style="list-style-type: none"> • Mount controller at eye-level for ease of operating Eagle 3.0 user interface. See step 7. • Optional: A universal adapter plate is available for mounting controller and FTW 174 / 175 to existing uni-strut. Refer to Figure 2-4 or call Flash for details. • Mount resistive PEC in upright position with unobstructed view of polar sky in accordance with FAA requirements. • Utilize #2 Phillips head and 1/8" flathead screwdrivers to connect beacon and marker cables to controller. Refer to page 14 for detailed connections. • Refer to Figures 2-10 & 2-11 for suggested cable routing. • Apply power to controller only after marker and beacon cables are connected at both ends. 	<p>4.</p> <div style="display: flex; justify-content: space-around; align-items: center;">    </div> <p style="text-align: center;">FH 370r</p> <ul style="list-style-type: none"> • Before installation, verify that the voltage selector switch, located on the power supply PCB of the FH 370r, matches the supply voltage to the system. See Section 1 for more details. • Flashhead should be hoisted by the mounting holes located in the base. Damage to the flashhead may occur if any other method is utilized. • There should be no obstructions in the horizontal path of the light output in accordance with FAA requirements. • Mount on a level surface to ensure light output in accordance with FAA requirements. • Ensure flashhead is electrically bonded to tower by installing on clean metal surface and utilizing stainless or galvanized hardware provided • Provide 5' flashhead cable service loop next to each beacon and controller. • Copper lighting rods should extend a minimum of 36" above top of beacon.

<p>5.</p> <p style="text-align: center;">CABLE</p>  <ul style="list-style-type: none"> • Attach marker and flashhead cables with special tape provided. Use of wire ties is not recommended. • Apply tape per 2-4-4 method. • NEC specifies tape intervals are not to exceed 5'. • Allow 1" excess cable around tower leg flanges to avoid abrasion. • Service loops are recommended as a precaution for future maintenance or diagnostics. 	<p>6.</p> <p style="text-align: center;">MARKER KIT</p> <ul style="list-style-type: none"> • Marker kit design eliminates need for conduit. • Install sections of marker cable and mount fixtures to universal brackets prior to climbing. • Universal bracket accommodates side and bottom mount fixtures. Note universal bracket secures side mount fixtures to maintain upright position. • Punch a small hole in center of applicable cord grips in junction box for marker cable installation. • Wire nuts are provided in the marker kit for marker cable connections in junction box and marker bases. • Install a drip loop for each cable near the junction box and at each marker fixture. • Confirm the controller programming matches the number of markers installed. <p style="text-align: center;">Refer to instructions provided in marker kit for detailed information.</p>
<p>7.</p> <p style="text-align: center;">EAGLE 3.0 INTERFACE</p>  <ul style="list-style-type: none"> • After initial power up, interface will display the factory-set system configuration. Confirm the configuration matches the system installed. • "Sys OK" followed by "Auto" should display next. This confirms there are no alarms detected and the PEC is set to "Auto" mode. • Refer to Section 3 to run Diagnostics, change the system Configuration or perform an automated or manual Lighting Inspection. 	<p>8.</p> <p style="text-align: center;">MONITORING/ALARMING</p>  <ul style="list-style-type: none"> • For Flash monitoring customers: Connect FTW 174 / 175 to RS485 communication located in controller. This connection is necessary for Quarterly Lighting Inspection (QLI) waiver. Refer to FTW manual for detailed interface connections. • Dry contact alarms are configured to alarm when the state is "open". For discrete alarming, a single common connection is provided in controller. • Dry contact alarms for markers, input power and PEC are located in the controller. Flash Technology's 19 hour fail-safe feature is associated with the PEC contact and must be utilized to capture a mode related alarm. <p style="text-align: center;">Refer to Section 2 for detailed wiring instructions.</p>

Installation Check List

CONTROLLER

- The controller is mounted away from radio frequency interference (RFI).
- The controller is mounted upright, water tight and lightning bonded to the site grounding system.
 - # 2 AWG wire (min.) is used to connect the grounding lug, located on the back-plate inside the enclosure, to the lightning ground system (tested for 25 ohms or less).
 - There are no holes punched or drilled in the top or sides of the enclosure.
 - All unused controller entry holes are capped or sealed with NEMA 4 connectors to maintain the rating of the enclosure.
 - Airflow can circulate around the enclosures. Allow 8 to 10" on all sides.
 - The top of the enclosure should be approximately eye level to facilitate easy access and troubleshooting.
- The supply voltage ranges from 120-240V AC and the supply frequency is 50 or 60 Hz.
- Input power is supplied by a dedicated circuit breaker which is sized to meet the load requirements of the lighting system per NEC guidelines.
- If a permanent power source is not available, a 1000 Volt Ampere (1 KVA) **minimum** generator, is used to supply power to the lighting system. The electrical supply frequency must be between 47 and 63 Hz.
- All electrical connections and mounting hardware, inside the controller, have been checked for tightness before powering the system on.
 - All installed wiring is securely connected to the appropriate terminals; without interference from the wire's insulation.
 - All PCB connectors are plugged in securely; wires properly inserted and screws tight in the controller.
- The Address Switch located on the MOD 1 board is set to position 1. The lowest beacon(s) should be connected to the MOD 1 board. Additional MOD X boards should be programmed as 2 -7.
- The uppermost beacon(s) are connected to the highest numbered MOD X RLC board. The AOL jumper is installed for all uppermost beacons (required only when used as part of a dual system).
- A MKR surge protector board is connected to the output of each MOD X board installed in the system.
 - The beacon(s) are connected to the BCN outputs of the Marker Surge Protector PCB(s) with the **jumpers intact for all beacon outputs.**
 - The markers are connected to the MKR output of the Marker Surge Protector PCB(s) with the **jumpers cut for all marker outputs.**
- The photocell is connected to terminals 4 & 5 of connector J4 located on PCB 1.
- The **Manual Mode** (Intensity Select) switch is set to the **Auto** position.

LED BEACON and Marker CABLE

- The LED beacon and marker cable has the outer insulation (black jacket) removed except leaving a 1" section of the jacket protruding past the entrance into the fixture.
 - The cord connectors are tight
- The cable's insulation has not been nicked.
- Each cable run has a service loop at the base of the tower; near the controller.
- The vertical cable runs, for all installed beacons and markers tiers, are secured to the tower structure as described below to prevent damage to the cables. See Section 2 *Securing the Cable* for additional information regarding installation of the cable.
 - The cable is secured to the structure using the supplied tape; following the method prescribed in Section 2 *Securing the Cable*
 - A service loop is placed just below the beacon or marker junction box.
 - The cable is not pulled tight against sharp edges.
 - The cable is secured on each side of every tower leg joint, or flange, allowing 1 inch of slack around the joint.

Beacons

- The voltage selector switch, located on the power supply of each FH 370r installed in the system, is set to match the supply voltage to the system.
- The LED beacon is wired correctly.
 - The dome nut on the cable strain relief is tight.
 - The LED beacon is securely closed with both latches in place.
- The top of the tower has a lightning rod(s) made of copper extending at least 36" above the top of the beacon.
- The LED beacon is level.
- The LED beacon is grounded to the tower using the Stainless Steel or Galvanized hardware provided.
- The LED beacon is mounted in an FAA approved location (no obstruction providing a 360° view).

MARKERS (L-810 LED sidelights)

- Only **LED 6.8 Watt L-810 Marker Fixtures** provided by Flash Technology are installed in the system.
- The marker junction box is securely mounted and installed as described in the instructions provided with the marker kit. The box is watertight and mounted with the connector holes down.
- The marker wires are sized sufficient so voltage drop to marker fixtures is 3% or less per FAA specifications. A drip loop is present at the junction box.

PHOTOCELL (PEC)

- The photocell mounted vertically to prevent water entry.
- The PEC cable is protected through conduit so it will not be stepped on or damaged.
- The PEC is facing north facing north and no artificial lights (*security lights, street lights, lighted signs, or direct sunlight*) will affect its operation.

ALARMS and ALARM WIRING

- No Alarm LEDs are lit on the Controller PCB 1 board or any MOD X board installed in the system.
- The controller user interface display panel is reading SYS OK and is displaying the correct configuration of the system installed on the structure. *See Section 3 System Configuration and Menu Options for additional information.*
- Perform a Diagnostic review and a Lighting Inspection via the user interface panel.
- Dry contact alarm wiring, if required, is connected to the alarm monitoring system as prescribed by the tower owner. *Refer to Figures 2-15 - 2-17 for examples of typical alarm wiring.*
- RS 485 monitoring conductors are installed if interfacing with an FTW 174 or FTW 175 Wireless Monitoring Unit. Refer to the FTW product manual for detailed instructions.

Call Flash Technology at 1-800-821-5825 if additional TECHNICAL ASSISTANCE is needed.

Front Matter

Abstract

This manual contains information and instructions for installing, operating and maintaining the FTS 361X-4 Red LED Obstruction Lighting System.

Copyright

Copyright © 2013, Flash Technology®, Franklin, TN, 37067, U.S.A.

All rights reserved. Reproduction or use of any portion of this manual is prohibited without express written permission from Flash Technology and/or its licensor.

Trademark Acknowledgements

Flash Technology® is a registered trademark name.

All trademarks and product names mentioned are properties of their respective companies, and are recognized and acknowledged as such by Flash Technology.

Applicable Specifications

This equipment meets or exceeds requirements for an FAA Type L-864.

Disclaimer

While every effort has been made to ensure that the information in this manual is complete, accurate and up-to-date, Flash Technology assumes no liability for damages resulting from any errors or omissions in this manual, or from the use of the information contained herein. Flash Technology reserves the right to revise this manual without obligation to notify any person or organization of the revision.

In no event will Flash Technology be liable for direct, indirect, special, incidental, or consequential damages arising out of the use of or the inability to use this manual.

Warranty

Flash Technology warrants all components of the LED lighting system, under normal operating conditions, for 5 years from the date of shipment from Flash Technology.

Parts Replacement

The use of parts or components, in this equipment, not manufactured or supplied by Flash Technology voids the warranty and invalidates the third party testing laboratory certification which ensures compliance with FAA Advisory Circulars 150/5345-43G, 150/5345-53D, and Engineering Brief No. 67D. The certification is valid as long as the system is maintained in accordance with FAA guidelines (FR doc. 04-13718 filed 6-16-04).

Personnel Hazard Warning

Dangerous Voltages

Dangerous line voltages reside in certain locations in this equipment. Also, this equipment may generate dangerous voltages. Although Flash Technology has incorporated every practical safety precaution, exercise extreme caution at all times when you expose circuits and components, and when you operate, maintain, or service this equipment.

Avoid Touching Live Circuits

Avoid touching any component or any part of the circuitry while the equipment is operating. Do not change components or make adjustments inside the equipment with power on.

Do Not Depend on Interlocks

Never depend on interlocks alone to remove unsafe voltages. Always check circuits with a voltmeter after turning the circuit breakers off. Under no circumstances remove or alter the wiring or interlock switches.

Table of Contents

Front Matter	i
Abstract.....	i
Copyright	i
Trademark Acknowledgements	i
Applicable Specifications	i
Disclaimer.....	i
Warranty	i
Parts Replacement	i
Personnel Hazard Warning	ii
Dangerous Voltages.....	ii
Avoid Touching Live Circuits	ii
Do Not Depend on Interlocks	ii
Table of Contents.....	iii
List of Figures.....	iv
List of Tables	iv
Section 1 – Introduction and Operation.....	1
Introduction.....	1
System Overview.....	1
Specifications.....	2
Controller.....	3
Controller (PCB1).....	4
RLC Output PCB (MOD X).....	7
RLC MKR Surge Protector	10
FH 370r.....	11
Section 2 – Mounting and Installation.....	13
Controller Installation.....	13
Mounting.....	13
Mounting Adapter Panel (Optional)	13
Wiring	14
RLC MKR Surge Protector	14
Beacon Mounting.....	15
Marker Mounting.....	16
Section 3 –System Configuration and Menu Options	37
Menu Overview	37
Configuring the System.....	37
Diagnostic Menu.....	39
Lighting Inspection Menu.....	41
Section 4– Maintenance and Troubleshooting	42
Safety	42
Preventive Maintenance.....	42
Storage	42
RFI Problems	42
Troubleshooting.....	42
Photocell Testing	44
Component Removal and Replacement.....	44
Controller.....	44

Beacon	44
Section 5 – Recommended Spare & Replaceable Parts.....	46
Customer Service.....	46
Ordering Parts.....	46
Replaceable Parts.....	46
Return Material Authorization (RMA) Policy.....	52

List of Figures

Figure 1-1 – Controller PCB (PCB1)	4
Figure 1-2 – Controller Display and User Interface	5
Figure 1-3 –RLC Output PCB (MOD X)	7
Figure 1-4 – Marker Surge Protector (PCB 3).....	10
Figure 1-5 – FH 370r Base (Internal)	12
Figure 2-1 – J1 Connector	15
Figure 2-2 – A-0 – A-2 Controller Mounting and Outline	19
Figure 2-3 – A-3 – A-6 Controller Mounting and Outline	20
Figure 2-4 – Adapter Mounting Panel Outline (optional item)	21
Figure 2-5 – Beacon Mounting Outline.....	22
Figure 2-6 – Photocell Mounting and Outline.....	23
Figure 2-7 – A-0 System Wiring Diagram	24
Figure 2-8 – A-1 System Wiring Diagram	25
Figure 2-9 – A-3 System Wiring Diagram	26
Figure 2-10 – A0 – A2 Suggested Controller Conductor Routing	28
Figure 2-11 – A3 – A6 Suggested Controller Conductor Routing	28
Figure 2-12 – A0 – A2 Controller Internal Wiring.....	29
Figure 2-13 – A3 – A6 Controller Internal Wiring.....	30
Figure 2-14 – FH 370R Internal Wiring.....	31
Figure 2-15 – Dry Contact Wiring Interface (Individual Alarm Points).....	32
Figure 2-16 – Dry Contact Wiring Interface (Limited Alarm Points A0-A2).....	33
Figure 2-17 – Dry Contact Wiring Interface (Limited Alarm Points A3-A6).....	34
Figure 2-18 – FTW 170 Wireless GPS System Wiring Diagram.....	35
Figure 2-19 – FTC 121 System Interface	36
Figure 5-1 – A0 – A2 FLC Controller Component Locations.....	47
Figure 5-2 – A3 – A6 FLC Controller Component Locations.....	48
Figure 5-3 – FH 370R Component Locations	50

List of Tables

Table 1-1 – Physical Specifications.....	2
Table 1-2 – Performance Specifications.....	2
Table 1-3 – FTS 361X-4 Red Lighting Systems	3
Table 1-4 – Controller Display Buttons.....	5
Table 1-5 – Status LEDS	6
Table 1-6 – J-Connector Interface	6
Table 1-7 – RLC Output PCB Connections	9
Table 1-8 – RLC Output PCB LED’s.....	9
Table 2-1 – Beacon Connections.....	16

Table 2-2 – Marker Connections	16
Table 3-1 –Top-Level Menu Options	37
Table 3-2 – Configuration Menu	38
Table 3-3 – Alarm Definitions.....	39
Table 3-4 – Diagnostic Status Menu	39
Table 3-5 – Beacon Diagnostic Menu	40
Table 3-6 – Marker Diagnostic Menu	40
Table 3-7 – Controller Diagnostic Menu.....	40
Table 3-8 – Lighting Inspection	41
Table 4-1 – Troubleshooting	43
Table 5-1 – Controller Replaceable Parts	49
Table 5-2 – Beacon Replacement Parts	51
Table 5-3 – Optional Parts.....	51

Section 1 – Introduction and Operation

Introduction

The FTS 361X-4 Red LED Obstruction Lighting System is designed to operate FAA type L-864 flashing LED beacons and L-810 flashing or steady burning side lights (markers). The FLC 361X-4 controller is available in two sizes: one designed to accommodate A0 – A2 systems (pictured below) and one designed to accommodate A3 – A6 systems. See Table 1-3 for a complete list of models.

System Overview

The FTS 361X-4 LED Lighting System has been designed for long life; reducing the need for service. In the event that service is required, the need for climbing is reduced by locating all control electronics on the ground. Ease of installation and service is enhanced by

simple wiring, setup, and diagnostics. Each lighting system consists of one controller and one or more LED beacons and / or LED side lights.

The controller provides mode control, synchronization of beacons, L-810 marker control and alarm interfaces. The controller's operational voltage ranges from 120 to 240 VAC 50/60 Hz without any modifications to the input power module. The FTS 361X-4 system is not phase sensitive relative to the input power.

This manual provides guidance and recommendations for the installation, operation, and troubleshooting of the lighting system. Please read this document in its entirety before installation.



Specifications

Table 1-1 – Physical Specifications

Parameter	
FLC 361X-4 Controller (A0 – A2) Dimensions (H x W x D) Weight	15.32 x 12.76 x 6.60 in 12 lbs
FLC 361X-4 Controller (A3 – A6) Dimensions (H x W x D) Weight	19.31 x 17.32 x 9.58 in 22 lbs (Max.)
FH 370r Beacon Dimensions (H x DIA) Weight	7.31 x 15.75 in 26.3 lbs
PEC 510 Photocell (H x W x Depth)	3.06 x 2.58 x 1.02 in

Table 1-2 – Performance Specifications

Parameter	
Application Flash Intensity (nominal)	L-864 2,000 ± 25% ECD
Flash Rate	User programmable 20/30 flashes per min.
Primary Power	120-240VAC, 50/60 Hz
Controller Power Consumption (A0 – A2)	12 W
Controller Power Consumption (A3 – A6)	24 W
Power Consumption L-864 FH 370r L-810 MKR 3601 L-810 MKR 3602	7 W 6.8 W 13.6 W
Environmental	Complies with FAA specifications in AC 150/5345-43F.

Table 1-3 – FTS 361X-4 Red Lighting Systems

	System Model Number*	Controller Model Number	Beacon Model Number	Marker Model Number	Number of Marker Tiers
A-0	FTS 361 <u>0</u>	FLC 3611-4	N/A	MKR 3602	1 (Double)
A-1	FTS 361 <u>1</u>	FLC 3611-4	FH 370r	MKR 3601	1
A1 Double	FTS 361 <u>2</u>	FLC 3611-4	FH 370r	MKR 3601	1
A-2	FTS 361 <u>3</u>	FLC 3612-4	FH 370r	MKR 3601	2
A-2 Double	FTS 361 <u>4</u>	FLC 3612-4	FH 370r	MKR 3601	2
A-4	FTS 361 <u>5</u>	FLC 3613-4	FH 370r	MKR 3601	3
A-4 Double	FTS 361 <u>6</u>	FLC 3613-4	FH 370r	MKR 3601	3
A-4	FTS 361 <u>7</u>	FLC 3614-4	FH 370r	MKR 3601	4
A-4 Double	FTS 361 <u>8</u>	FLC 3614-4	FH 370r	MKR 3601	4
A-5	FTS 361 <u>9</u>	FLC 3615-4	FH 370r	MKR 3601	5
A-5 Double	FTS 361 <u>10</u>	FLC 3615-4	FH 370r	MKR 3601	5
A-6	FTS 361 <u>11</u>	FLC 3616-4	FH 370r	MKR 3601	6
A-6 Double	FTS 361 <u>12</u>	FLC 3616-4	FH 370r	MKR 3601	6
A-6 3 Top	FTS 361 <u>13</u>	FLC 3617-4	FH 370r	MKR 3601	6
A-6 4 Top	FTS 361 <u>14</u>	FLC 3617-4	FH 370r	MKR 3601	6
A-6 5 Top	FTS 361 <u>15</u>	FLC 3617-4	FH 370r	MKR 3601	6

*Underlined digit(s) indicates the total number of Beacons that can be connected to the controller.

Controller

Operation Overview

The controller component layout is shown in Figures 5-1 & 5-2 and the wiring diagram is shown in Figures 2-12 & 2-13.

The incoming AC Line (120-240 VAC 50/60Hz) is connected to terminal strip TB1. Mounted on TB1 is a Metal Oxide Varistor (MOV1) which reduces line surges and transients. Input power fuses F1 and F2 are also mounted on TB1. Disconnect power from the controller before servicing the fuses or MOV. The fuse holders in the A0 – A2 controller are hinged on the upper side. Lift and open

the side cover to access the fuse. The fuse holders in the A3 – A6 controller are hinged on the lower side. Pull down on the fuse holder to expose the fuse.

The Power Supply (PCB2) converts AC input power to 12VDC for the controller, PCB (PCB1) and RLC Output PCB's (MOD X).

The controller PCB (PCB1) supervises system operation. A user interface with alphanumeric display and pushbuttons provides system configuration and alarm notification.

Controller (PCB1)

PCB1 controls and monitors the operation of the FLC 361X-4 controller. Each

section of PCB1 outlined in Figure 1-1 is discussed in the following subheadings.

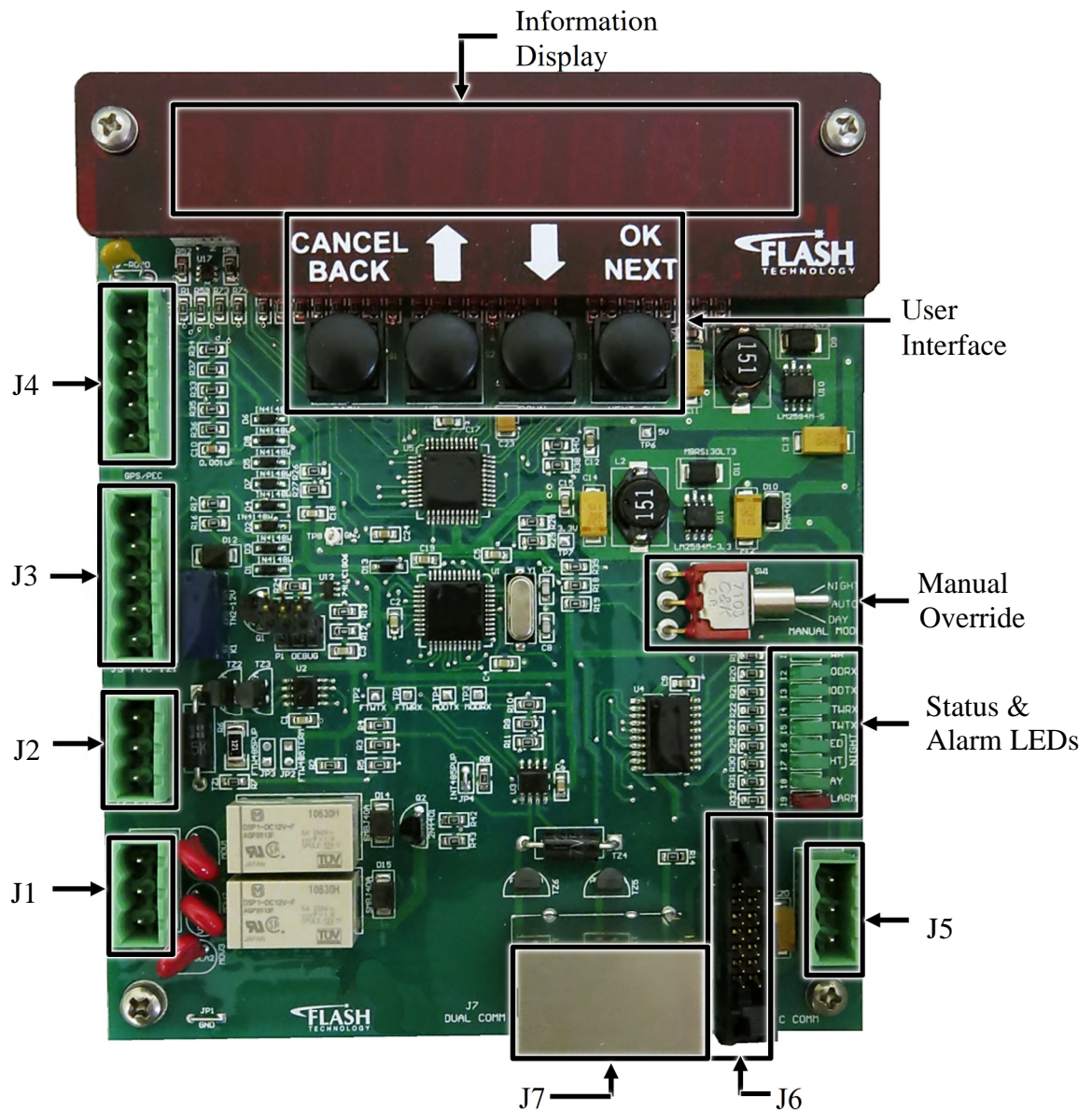

Figure 1-1 – Controller PCB (PCB1)

Controller PCB1 Information Display and User Interface



Figure 1-2 – Controller Display and User Interface

An eight character display located on PCB1 provides system status and alarm information. The default display alternates between system status, operating mode and the current system configuration. An example of the system display with no alarms present is: “SYS OK”, “AUTO” and “CURRENT CONFIG - TYPE-RED-BEACONS 1 MKR TIERS 1 - MKR/TIERS 3”.

When present, alarms will be displayed instead of “SYS OK”. See Table 3-3 for a list of possible alarms and their definitions.

Four buttons, located below the information display, provide the user interface for programming and diagnostic review. Table 1-4 provides a description for each button’s function.

Table 1-4 – Controller Display Buttons

Button	Function
CANCEL / BACK	Returns BACK to a previous screen or CANCELS a previous command.
UP ↑	Navigates UP through the active menu options.
DOWN ↓	Navigates DOWN through the active menu options.
OK / NEXT	OK Confirms your selection or Advances to the NEXT option.

Controller Manual Override

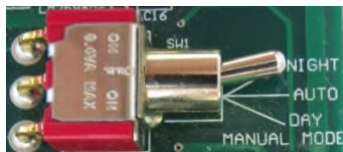

When the Manual Mode switch is moved to either Day or Night, the display reads “MANUAL” and the corresponding Mode LED blinks. Manual mode on the system controller

expires 30 minutes after initiating the mode override. Each change to the manual mode switch restarts the 30 minute timeout. The Manual Mode switch must be moved after power up to activate mode override. The switch has no effect if it is set to Day or Night before power up.

Status LEDs

Nine Status and Alarm LEDs are provided for immediate visual reference of the

current status of the unit. Table 1-5 describes the function of each LED.

Table 1-5 – Status LEDs



LED	Indication
PWR (I1)	Green when power is applied to the controller
MODRX (I2)	Green blinking when controller is receiving data from the RLC Output PCB(s)
MODTX (I3)	Green blinking when controller is sending data to the RLC Output PCB(s)
FTWRX (I4)	Green blinking when controller is receiving data from an attached FTW wireless unit
FTWTX (I5)	Green blinking when controller is sending data to an attached FTW wireless unit
NIGHT RED (I6)	Green continuous when controller is in RED NIGHT mode; blinking when controller is in manual RED NIGHT.
NIGHT WHT (I7)	(Night White) Not used in this application.
DAY (I8)	Green continuous when controller is day mode; blinking when controller is in manual day mode.
ALARM (I9)	Red when controller has detected a fault.

Table 1-6 – J-Connector Interface
(See Figure 1-1)

Connector	Function
J1	Dry Contact Alarm Outputs 1- Photocell – closed when the photocell has changed modes (day/night) within the last 19 hours. 2- Power Fail – closed when power is applied 3- Alarm Common
J2	RS 485 for FTW 174/175 wireless monitoring unit connectivity only.
J3	FTC 121 High Intensity interface / Mode relay connection. (See Figure 2-19)
J4	Resistive photocell input (See Figures 2-7 – 2-9) & FTW 170 wireless sync. (See Figure 2-17)
J5	12VDC power input
J6	RS-485 Communication and 12VDC power output to RLC interface PCB's
J7	Not used in this application.

RLC Output PCB (MOD X)

The Red Light Controller Output PCB, referred to as MOD X (Module + board number), drives two L-864 beacons and one tier of L-810 markers. Each output is individually fused. The output board also

provides dry contact alarm outputs for each connected beacon and marker tier. Each section of the MODX PCB, outlined in Figure 1-3, is discussed in the following sub-headings and Tables.

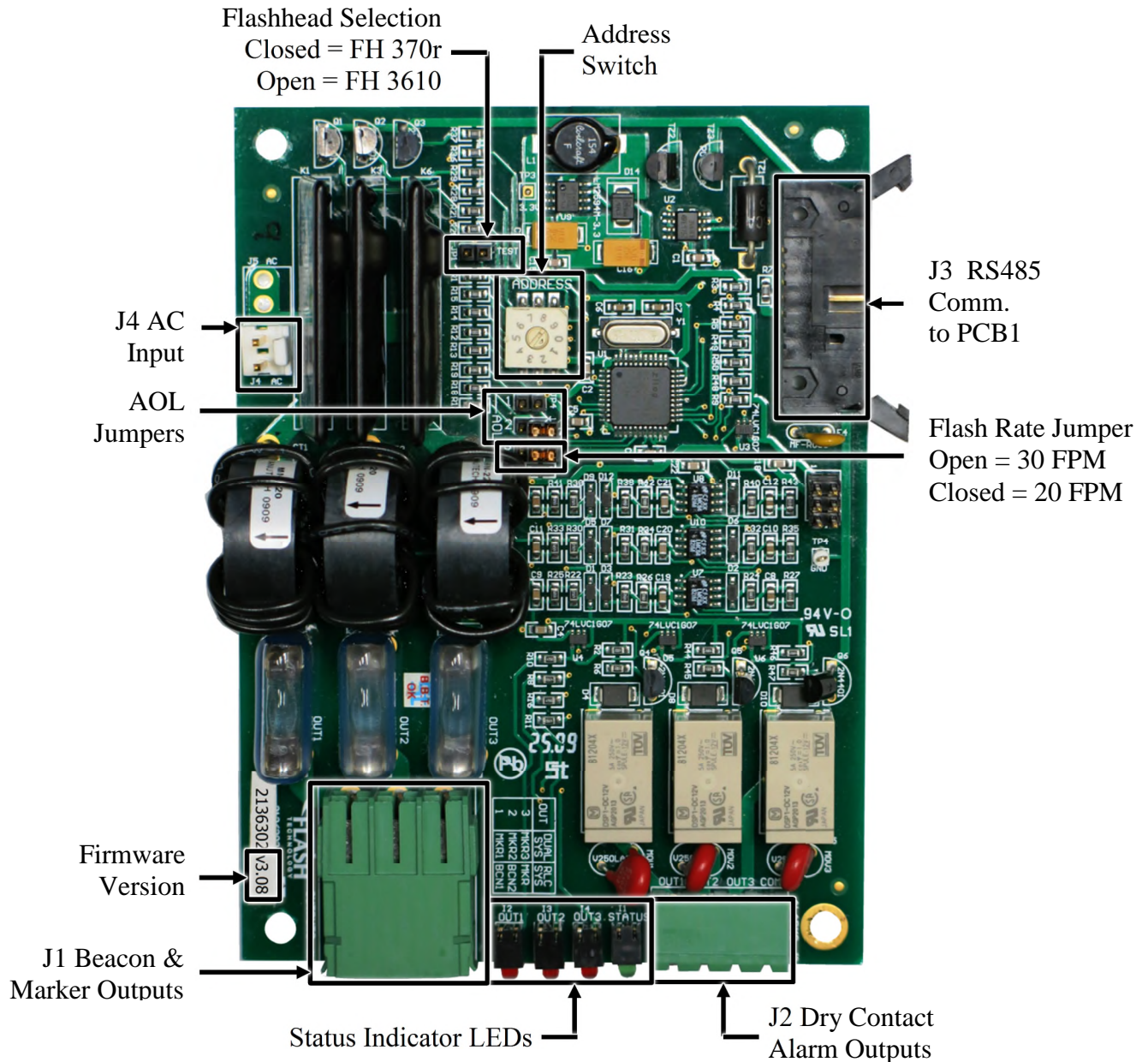
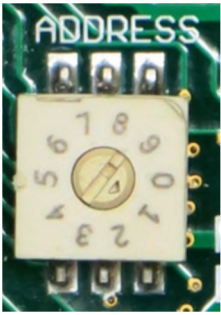

Figure 1-3 –RLC Output PCB (MOD X)

Address Switch



Each MOD X PCB must have a unique address (1-7) which is factory preset for new systems. Typically, the MOD X board connected to Beacons 1 & 2 will be programmed for

Address 1. The MOD X board connected to Beacons 3 & 4, if installed, will be programmed for address 2 and will continue this pattern for all MOD X boards installed in the system. If it becomes necessary to replace any MOD X board, use a 1/8" flat-head screwdriver to adjust the rotary switch to match the configuration of the original board.

Flashhead Selection (JP1)

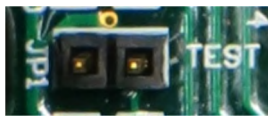

JP1, located above the Address Switch, allows the MOD X board to control and

monitor the current FH 370r or the legacy FH 3610. The default setting for JP1 is closed (installed on both pins) allowing the MOD X board to control and monitor up to two FH 370r units. The jumper must be open (installed on one pin) when the MOD X board is used to control and monitor the legacy FH 3610.

Note: JP1 sets the monitoring parameters for both beacon outputs on the MOD X board. Connect only one beacon type (FH 370r or FH 3610) to each MOD X PCB.

AOL Jumpers

When interfaced with an FTC 121 controller, as part of a dual lighting system, the FTS 361X-4 system



must be configured so that malfunction of any uppermost L-864 beacon signals the entire system to operate in white night mode.

AOL jumpers, located on the MOD X board allow any beacon to be configured to meet this requirement. The jumpers labeled AOL 1 & 2 (JP4 & JP5) correspond to output terminals J1 1 & 2 listed in Table 1-7. To configure the AOL jumper(s), locate the MOD X board outputs connected to all uppermost L-864 beacons and install the jumper over both of the corresponding pins.

Flash Rate Selection (JP6)

JP6 (AOL 3), located next to AOL jumpers 1 & 2,



selects the flash rate of the attached beacon(s). With the jumper removed (open), the connected beacon(s) will flash at a rate of 30 flashes per minute. This is the default setting.

If the system will be synchronized with previous generations of Flash Technology equipment, requiring the system to flash at a rate of 20 flashes per minute, the jumper should be installed over both pins (closed).

Note: Only RLC Output PCB's (PN 2136302) with firmware version 3.08 or higher should be installed in the FTS 361X-4 system. JP3 must be set to the same position (open or closed) on each RLC Output PCB installed in the system.

Table 1-7 – RLC Output PCB Connections

Connector	Function
J1 Beacon & Marker Outputs	1- Beacon 1 (3,5,7,9,11,13) 2- Beacon 2 (4,6,8,10,12,14) 3- Marker Tier 1(2,3,4,5,6, Beacon 15)
J2 Dry Contact Alarm Outputs	1- Beacon 1 (3,5,7,9,11,13) 2- Beacon 2 (4,6,8,10,12,14) 3- Beacon Alarm Common 4- Marker Tier 1(2,3,4,5,6, Beacon 15) 5- Marker Alarm Common
J3	RS-485 Communication and 12VDC power input from controller PCB
J4	AC Input

Table 1-8 – RLC Output PCB LED's

LED	MOD X Indication
OUT 1	Illuminated if the beacon connected to Output 1 is in alarm condition
OUT 2	Illuminated if the beacon connected to Output 2 is in alarm condition
OUT 3	Illuminated if the marker tier (or beacon 15) connected to Output 3 is in alarm condition
STATUS	Flashes once every 3 seconds if communicating with controller PCB1

RLC MKR Surge Protector

The RLC Marker Surge Protector PCB is plugged directly into J1 of the MOD X RLC Output PCB and is intended to provide additional protection for the marker output only. Connections to the beacon(s) and markers are made at the J1

connector of the RLC Marker Surge Protector PCB. The protection circuit is enabled by cutting the jumper(s) shown in Figure 2-1. **Only jumpers associated with marker outputs, typically JP3 in this application, should be cut.**

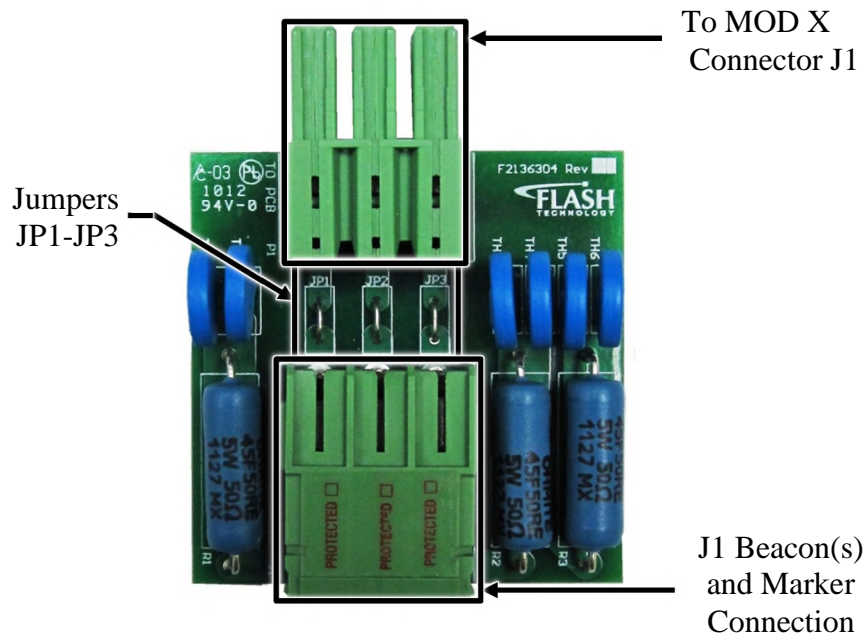

Figure 1-4 – Marker Surge Protector (PCB 3)

Important: The Marker Surge Protector PCB is intended to provide additional protection for marker output(s) on the MOD X RLC Output PCB (Part No. 2136302). Each of the three (3) outputs can be configured independently to match the configuration of the lighting system. The Marker Surge Protector PCB is **not** intended to provide additional protection for beacon output(s) on the MOD X RLC Output PCB. Improper operation of the beacon and / or damage to the marker surge protector PCB may occur if the protection circuit is enabled for beacon outputs.

FH 370r

The FH 370r, shown in the pictorial to the right, is divided into two sections: the LED output module and the base assembly. The LED output module is comprised of 36 highly efficient red LEDs whose output is focused to produce the required output per FAA specifications for type L-864 beacons. In the event service is required, the LED output module is field replaceable as a single assembly. The flashhead component layout is shown in Figure 5-3 and the wiring diagram is shown in Figure 2-14.

Figure 1-5 provides an overhead view of the base assembly. Located in the base is a terminal block for input power connections and a power supply that converts the input AC voltage to the appropriate DC output. Mounted on the terminal block are two surge suppression units. A window in the top right corner of each surge suppression unit indicates its status. During normal operation, the window will appear dark. If the surge suppressor fails, the window will turn red; indicating that the surge suppression units should be replaced immediately.



The power supply can operate from 115V or 230V AC. The power supply must be configured for the correct AC supply voltage before power is applied.

A selector switch is marked to indicate the voltage that the power supply is configured for. Use a flathead screwdriver to move the selector switch to match the input voltage to the flashhead.



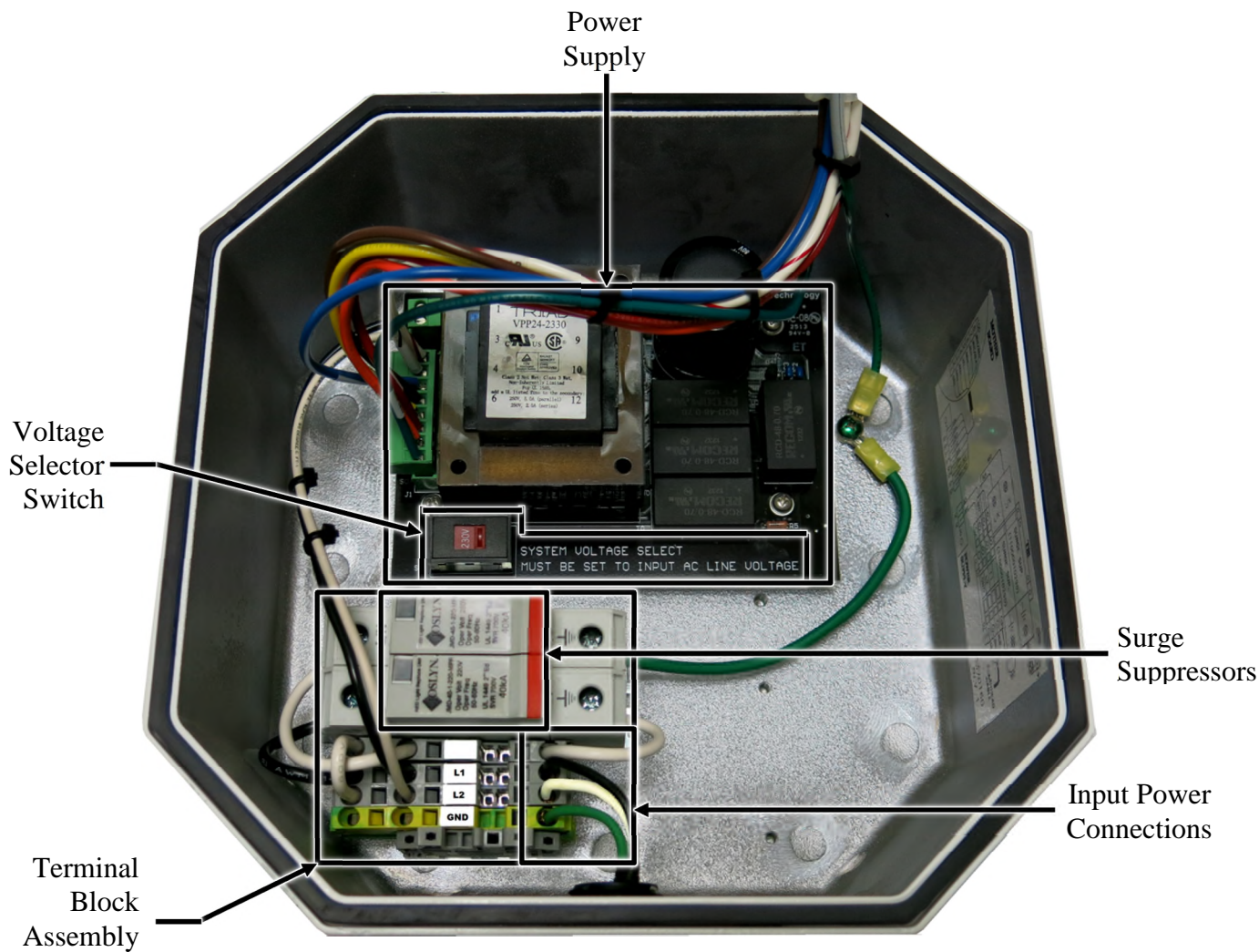

Figure 1-5 – FH 370r Base (Internal)

Important: Before applying power to the system, set the voltage selector switch, located on the power supply PCB in the FH 370r, to match the supply voltage to the system. Damage to the flashhead may result if the power supply voltage does not match the supply voltage to the system.

Section 2 – Mounting and Installation

Unpacking

Inspect shipping cartons for signs of damage before opening them. Check package contents against the packing list and inspect each item for visible damage. Report damage claims promptly to the freight handler.

Tools

Flash Technology suggests the following tools for installation and maintenance:

- 1/8" non-flared flat blade screw driver
- 9 or 12 inch, flat blade #2 screwdriver
- #2 Phillips® head screwdriver
- Set of combination wrenches
- Long-nose pliers
- Assorted nut driver handles: 1/4", 5/16", 3/8" recommended
- Digital volt-ohm meter
- Wire strippers

Controller Installation

See System Wiring Diagram Figures 2-7, 2-8 and 2-9 for additional installation requirements.

Personnel Hazard WARNING

Read the warning on Page ii now. Disconnect primary power before opening enclosures.

Verifying the Installation

Upon completion of the system installation, verify the main menu display shows the correct configuration. Enter the Diagnostic Menu and confirm that no alarms or errors exist and the configuration matches the system requirements.

Enter the Lighting Inspection Menu after installing or servicing the equipment and verify that the system is operating correctly.

Controller

Latches secure the controller's cover. Release the latches and open the cover for internal access.

Mounting

Flash Technology does not furnish mounting hardware unless ordered as part of an installation kit. Use the following guidelines for mounting the controller. Ensure that adequate space exists around the equipment for access during installation, maintenance and servicing. Allow space for airflow around the controller. See Figures 2-2 and 2-3 for controller enclosure dimensions and mounting feet.

Mounting Adapter Panel (Optional)

The optional Mounting Adapter Panel, shown in Figure 2-4, allows for easier installation of the FTS 361X-4 system by removing the need to modify the existing outdoor H-Frame when upgrading from previously installed Flash Technology products. The H-Frame may require adjustment on non-Flash Technology lighting products. The adapter panel may also simplify new installations. Please contact the Flash Technology parts department at 1-800-821-5825 if this option is desired.

Wiring

This manual may not contain all of the wiring information required for your installation.

Note: Flash Technology wiring diagrams define only minimum requirements recommended for satisfactory equipment operation. It is the responsibility of the installer to comply with all applicable electrical codes. You can find conduit and other distribution wiring details on electrical installation diagrams provided by Flash Technology or others. Installation instructions concerning L810 marker fixtures are not part of this manual. All installation wiring should have an insulation rating of 600 volts. Size input power wiring to satisfy the load demand of the system controller. Read the notes on the installation wiring diagrams supplied both in this manual and with the equipment.

If installation drawings prepared specifically for your site disagree with information provided in this manual, the installation drawings should take precedence. Consult any site-specific installation wiring diagram supplied with your equipment.

AC Line

The AC Line connections are made to TB1 in the lower right of the cabinet. The controller operates from universal input power (120-240V AC 50/60Hz) with no configuration necessary. Using a 1/8" non-flared flat blade screw driver, connect L1, L2, and Ground. AC input power conductor size depends on the service voltage, the distance from the source, number of L-864 LED beacons and L-810 LED marker lights served. Use 7.8 VA per LED beacon plus 7.5 VA for each L-810 marker light.

Important! For proper operation and optimal protection from Lighting and EMI, ensure that Earth Ground is wired to the Ground (Green) Terminal.

Photocell Wiring

The photocell input is located on connector J4 of PCB1 at terminals 4 & 5. The photocell is supplied with pigtails for connection to the controller and may be located any practical distance from the controller. The standard photocell (Part # 1855001) is supplied with 20' of cable. Photocells with cable lengths up to 75' are available. Also, the cable may be spliced to provide additional length. The recommended minimum wire gauge is #16 AWG if additional length is necessary.

Photocell Mounting

Mounting and outline dimensions for the photocell are shown in Figure 2-6. The photocell uses a male 1/2" NPT for mounting. Use the following guidelines to mount the photocell:

- Locate the photocell where it has an unobstructed view of the polar sky.
- It must not view direct or reflected artificial light.
- The photocell may be supported directly by electrical conduit.
- Ensure that the photocell cable is protected from possible damage and the installation is watertight.

RLC MKR Surge Protector

Connections to the beacon(s) and markers are made at connector J1 of the RLC Marker Surge Protector PCB. The protection circuit is enabled by cutting the jumper(s) shown in Figure 1-4. **Only jumpers associated with marker outputs, typically JP3 in this application, should be cut.**

Beacon Connections

As noted previously, beacon output connections are made at J1 located on the RLC Marker Surge Protector PCB. The connector should be removed from the PCB to ease wire installation. See Figure 2-1 for more information. Multiple connection points for L2F (Neutral) are provided on the leftmost positions of terminal strip TB1. Connection diagrams are provided in Figures 2-8 and 2-9. Table 2-1 provides a list of beacon connections by controller model. Only Flash Technology supplied LED FH 370R or FH 3610 L-864 beacons may be installed with this controller.

NOTE: JP1 on the MOD X board must be open (installed on one pin) if connecting to an FH 3610. See *Flashhead Selection* in Section 1 for additional details. See FTS 361X-3 Rev 1 Manual for specific details regarding the FH 3610-X beacon.

Beacon Mounting

Flash Technology recommends the installation of one or more lightning rods near the installed beacon. The lightning rods should extend a minimum of three feet above the height of the beacon.

The beacon is mounted to the tower pedestal utilizing 1/2" galvanized (Flash Technology part 5991740) or stainless steel hardware. Four mounting holes are provided on the beacon base as shown in Figure 2-5. The mounting holes will align with most tower pedestals. The beacon must be installed level to maintain light output in accordance with FAA requirements. Ensure the Flash Head is electrically bonded to the tower.

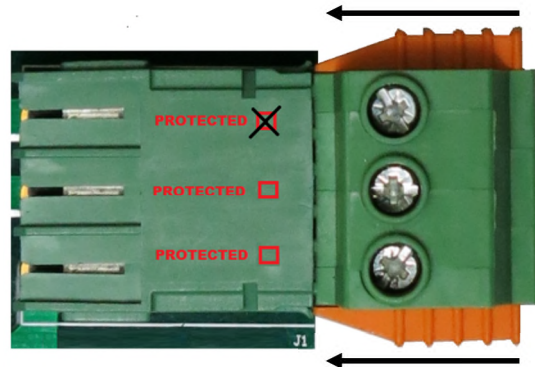

Slide the orange release mechanisms toward the PCB to disengage the locking tabs. Hold the Surge PCB firmly and pull the connector body to remove it from J1.

Figure 2-1 – J1 Connector

Table 2-1 – Beacon Connections

System Type	Beacon	L1	L2	Ground
A-1 – A-6	1	MOD 1 - J1 - Terminal 1	TB1- L2F Fused	Ground bus bar
A-1 Double – A-6	2	MOD 1 - J1 - Terminal 2	TB1- L2F Fused	Ground bus bar
A-2 – A-6	3	MOD 2 - J1 - Terminal 1	TB1- L2F Fused	Ground bus bar
A-2 Double – A-6	4	MOD 2 - J1 - Terminal 2	TB1- L2F Fused	Ground bus bar
A-4 – A-6	5	MOD 3 - J1 - Terminal 1	TB1- L2F Fused	Ground bus bar
A-4 Double – A-6	6	MOD 3 - J1 - Terminal 2	TB1- L2F Fused	Ground bus bar
A-4 – A-6	7	MOD 4 - J1 - Terminal 1	TB1- L2F Fused	Ground bus bar
A-4 Double – A-6	8	MOD 4 - J1 - Terminal 2	TB1- L2F Fused	Ground bus bar
A-5 – A-6	9	MOD 5 - J1 - Terminal 1	TB1- L2F Fused	Ground bus bar
A-5 Double – A-6	10	MOD 5 - J1 - Terminal 2	TB1- L2F Fused	Ground bus bar
A-6	11	MOD 6 - J1 - Terminal 1	TB1- L2F Fused	Ground bus bar
A-6 Double	12	MOD 6 - J1 - Terminal 2	TB1- L2F Fused	Ground bus bar
A-6 (3 Top)	13	MOD 7 - J1 - Terminal 1	TB1- L2F Fused	Ground bus bar
A-6 (4 Top)	14	MOD 7 - J1 - Terminal 2	TB1- L2F Fused	Ground bus bar
A-6 (5 Top)	15	MOD 7 - J1 - Terminal 3	TB1- L2F Fused	Ground bus bar

Note: Jumpers JP1 – JP3 located on the Marker Surge Protector PCB **should not be cut for any output connected to a beacon.** See Section 1 “RLC MKR Surge Protector” for additional information.

Marker Connections

Marker output connections are made at J1 located on the RLC Marker Surge Protector PCB. The connector should be removed from the PCB to ease wire installation. See Figure 2-1 for more information. Multiple connection points for L2F (Neutral) are provided on the leftmost positions of terminal strip TB1. Connection diagrams are provided in Figures 2-7 - 2-9. Table 2-2 provides a list of marker connections by controller

model. Only Flash Technology Supplied LED MKR 3601 6.8 Watt L-810 markers may be installed with this controller.

Marker Mounting

The marker fixtures should be attached to the structure utilizing the marker mounting brackets provided with the marker kit. Please refer to the drawing supplied with the marker kit for installation instructions.

Table 2-2 – Marker Connections

System Type	Marker Tier	L1	L2	Ground
A0 – A6	1	MOD 1 - J1 - Terminal 3	TB1- L2F Fused	Ground bus bar
A2 – A6	2	MOD 2 - J1 - Terminal 3	TB1- L2F Fused	Ground bus bar
A3 – A6	3	MOD 3 - J1 - Terminal 3	TB1- L2F Fused	Ground bus bar
A4 – A6	4	MOD 4 - J1 - Terminal 3	TB1- L2F Fused	Ground bus bar
A5 – A6	5	MOD 5 - J1 - Terminal 3	TB1- L2F Fused	Ground bus bar
A6	6	MOD 6 - J1 - Terminal 3	TB1- L2F Fused	Ground bus bar

Note: Jumpers JP1 – JP3 located on the Marker Surge Protector PCB **should be cut for any output connected to a marker tier.** See Section 1 “RLC MKR Surge Protector” for additional information.

Address Switch

The Address switch located on the MOD X RLC board must be set to the corresponding address. See Figure 1-3 for switch location and Figures 4-1 and 4-2 for the MOD X board location(s). The address is preset from the factory but should be confirmed during installation.

Dry Contact Alarm Outputs

Dry contact alarm outputs for the controller are available if the system is not monitored via Flash Technology's FTW 174 or FTW 175 RS 485 communication. The alarm contacts are standard as Normally Closed equals no alarm. Figures 2-15 - 2-17 provide examples of interface connections to the FTW 174/175's alarm inputs. Connections to monitoring equipment manufactured by others will vary. Consult documentation supplied by the monitoring equipment's manufacturer for specific information regarding connection to their equipment.

Photocell and power failure alarm outputs are available on PCB1 connector J1. A common connection is provided for both alarm points. Alarm outputs for each tier of beacons and markers are provided on the corresponding MOD X board. A common connection is provided for both beacon alarm points. A separate common connection is provided for the marker tier.

NOTE: The alarm relay contacts are labeled to represent their state with the unit powered on and with no alarms present.

To ensure proper alarm monitoring, Flash Technology recommends monitoring contacts that are open in an alarm condition.

Consult documentation supplied by the monitoring equipment's manufacturer for specific information regarding connection to their equipment.

Securing the Cable

Flash Technology recommends the following method for securing the beacon and marker cable to a skeletal structure:

1. Run the cable along one of the tower legs and wrap two full turns of two-inch Scotchwrap™ #50 tape, or the equivalent, around the cable and tower leg at regular intervals of about 5 feet (1.5 meters).

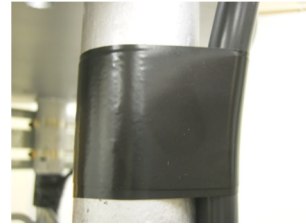

2. Wrap three full turns of one-inch Scotchwrap Filament #890 tape, or the equivalent, over the Scotchwrap #50 tape.

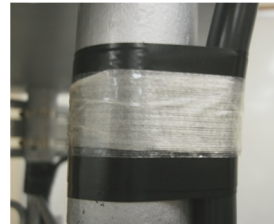

3. Wrap four full turns of two-inch Scotchwrap #50 tape, or the equivalent, over the Scotchwrap Filament #890 tape.

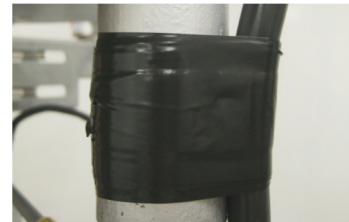

4. Perform steps 1 through 4 directly above and below any tower leg flanges that the cable may cross. The cable should be spaced approximately 1 inch from the edge of each flange to provide stress relief from vibration that may damage the jacket of the cable. A 5 foot service loop should be located near the beacon and the controller.

FTW 174 / FTW 175 Wireless Unit Communication

The RS 485 connections for the FTW Wireless Unit are located on connector J2 of PCB1. Previous versions of the FTW Monitoring units will not interface through RS 485. Refer to the FTW 174 or FTW 175 manual for installation instructions.

FTW 170 Wireless GPS Sync Input

The wireless sync input connection is located on connector J4 of PCB1. Refer to Figure 2-18 and the FTW 170 Wireless GPS manual for installation instructions.

FTC 121 System Controller Interface

The connections for interfacing the FTS 361X-4 system with an FTC 121 System Controller are on J3. This interface will allow the FTC 121 to start or stop the operation of the FLC 361X-4 controller based on the ambient light level. It will also monitor operation of the uppermost red beacon(s) and set the system to white night mode in the event of a failure. Refer to Figure 2-19 and the FTC 121 System Controller manual for additional information.

NOTE: To insure compliance with FAA guidelines, the AOL jumper(s) (JP4 & JP5) must be installed (closed) for all uppermost beacons installed in the system. Refer to Section 1 *AOL Jumpers* and Figure 1-3 for additional information.

The FTC 121 provides mode control for the FLC 361X-4 controller. A PEC 510 photocell should not be connected to the FLC 361X-4 controller when it is interfaced with an FTC 121 controller.

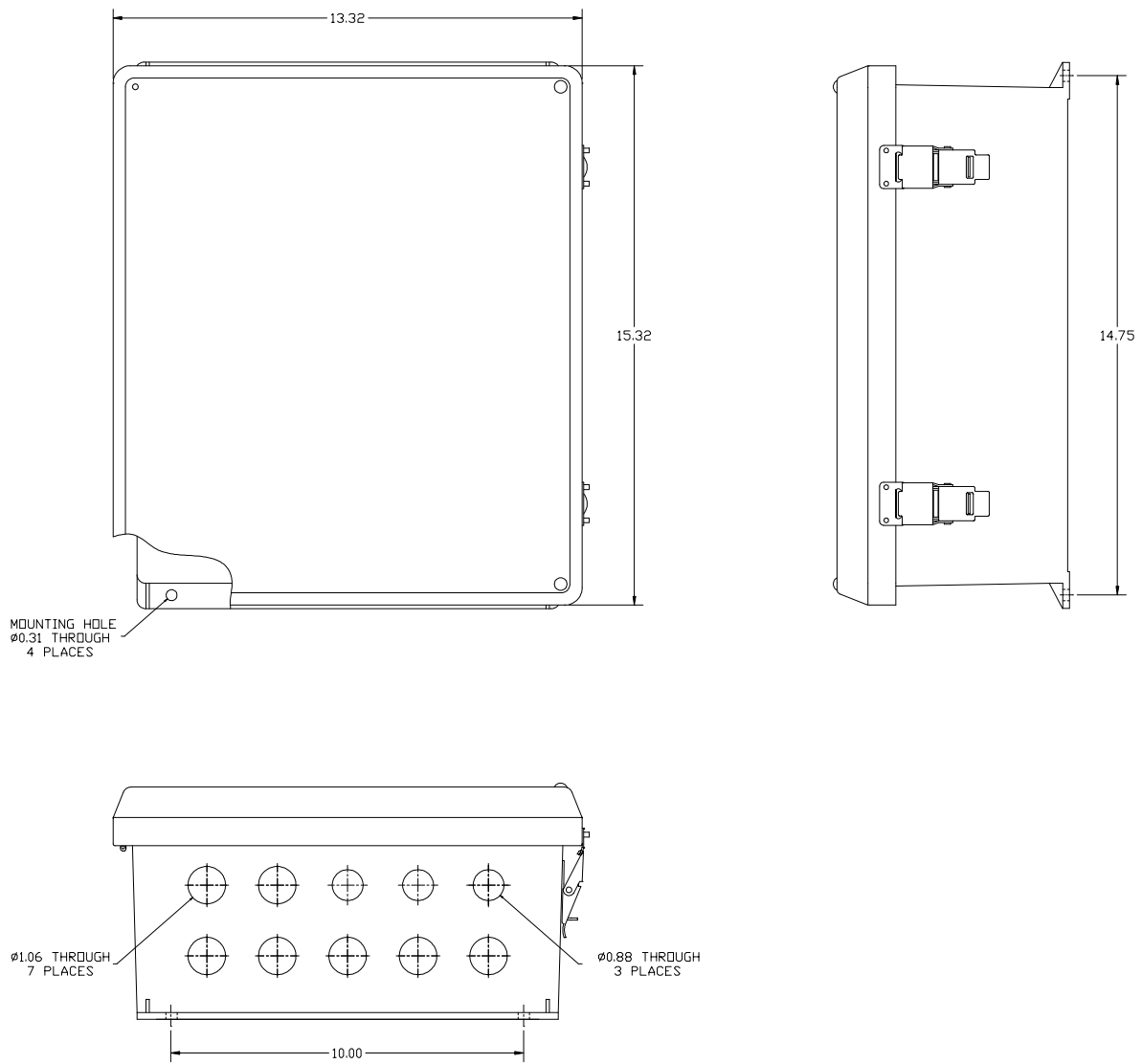

Figure 2-2 – A-0 – A-2 Controller Mounting and Outline

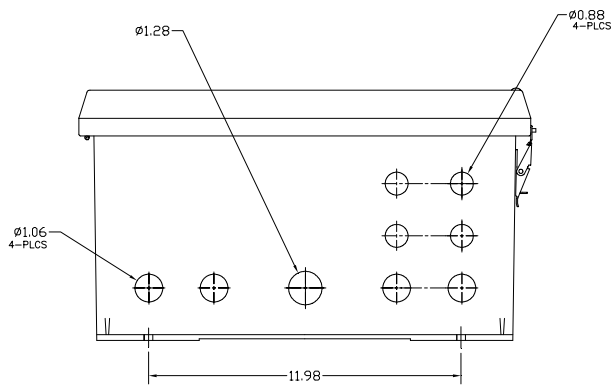
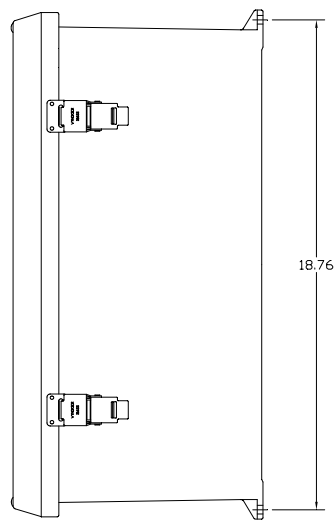
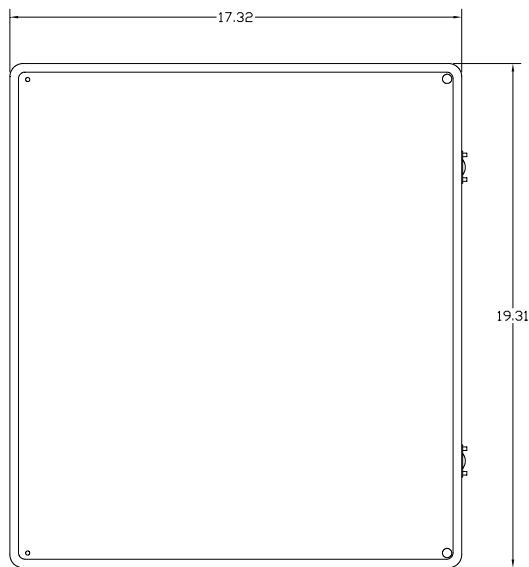
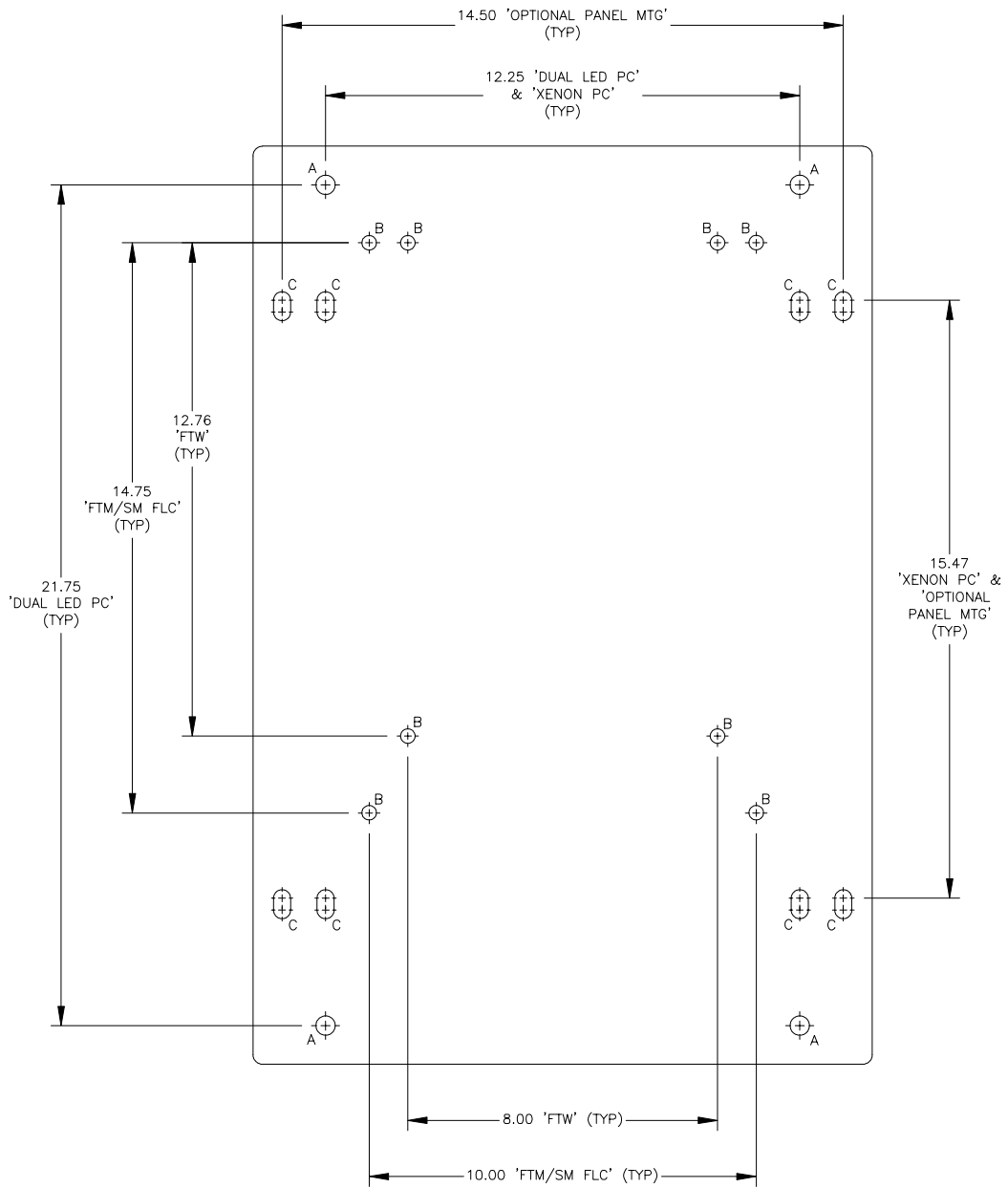

Figure 2-3 – A-3 – A-6 Controller Mounting and Outline



HOLE CHART		
LETTER	HOLE SIZE	QTY
A	0.50" DIA THRU	4
B	0.38" DIA THRU	8
C	ø0.44" X 0.75" LG SLOT THRU	8

Figure 2-4 – Adapter Mounting Panel Outline (optional item)

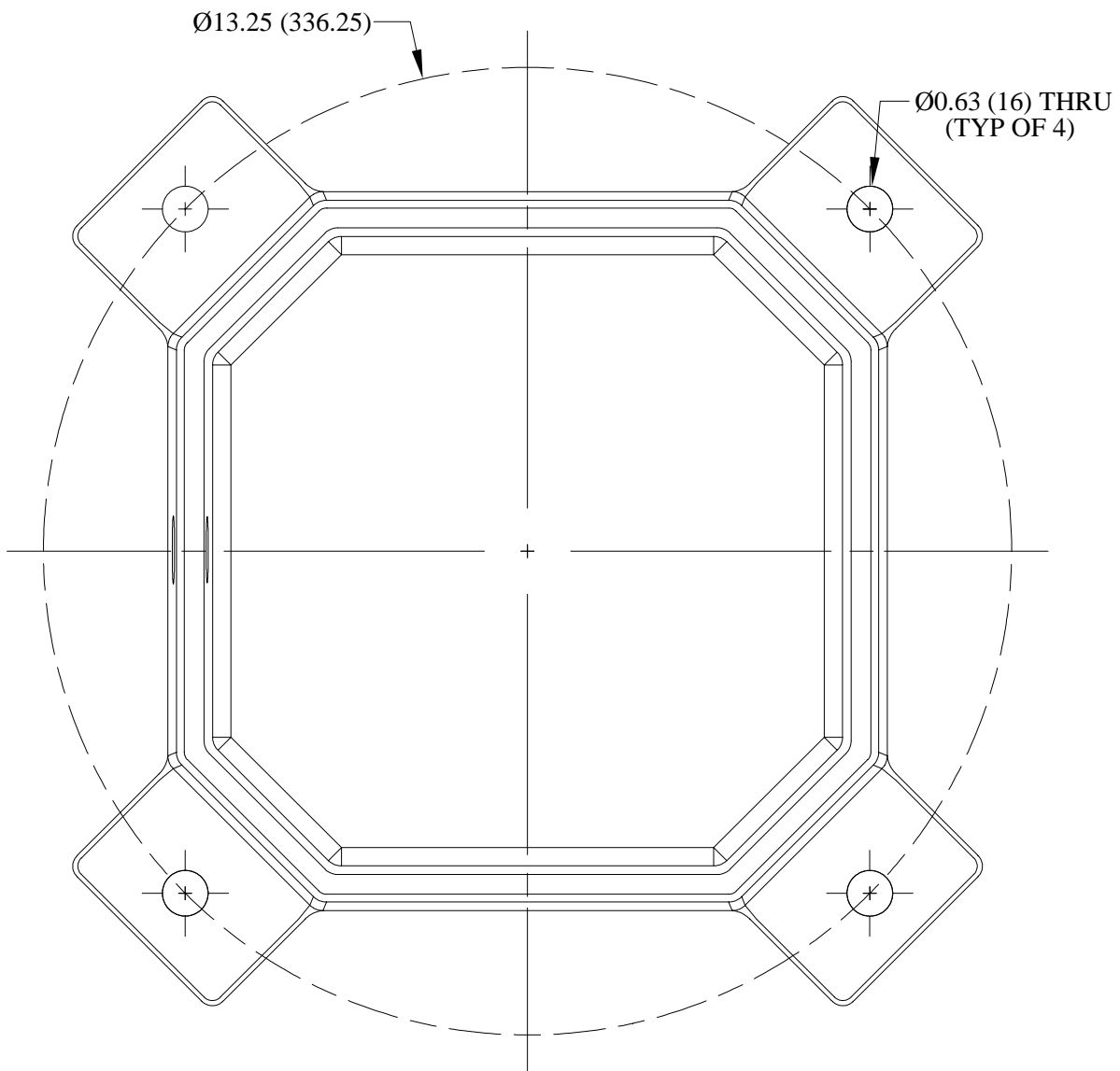

Figure 2-5 – Beacon Mounting Outline

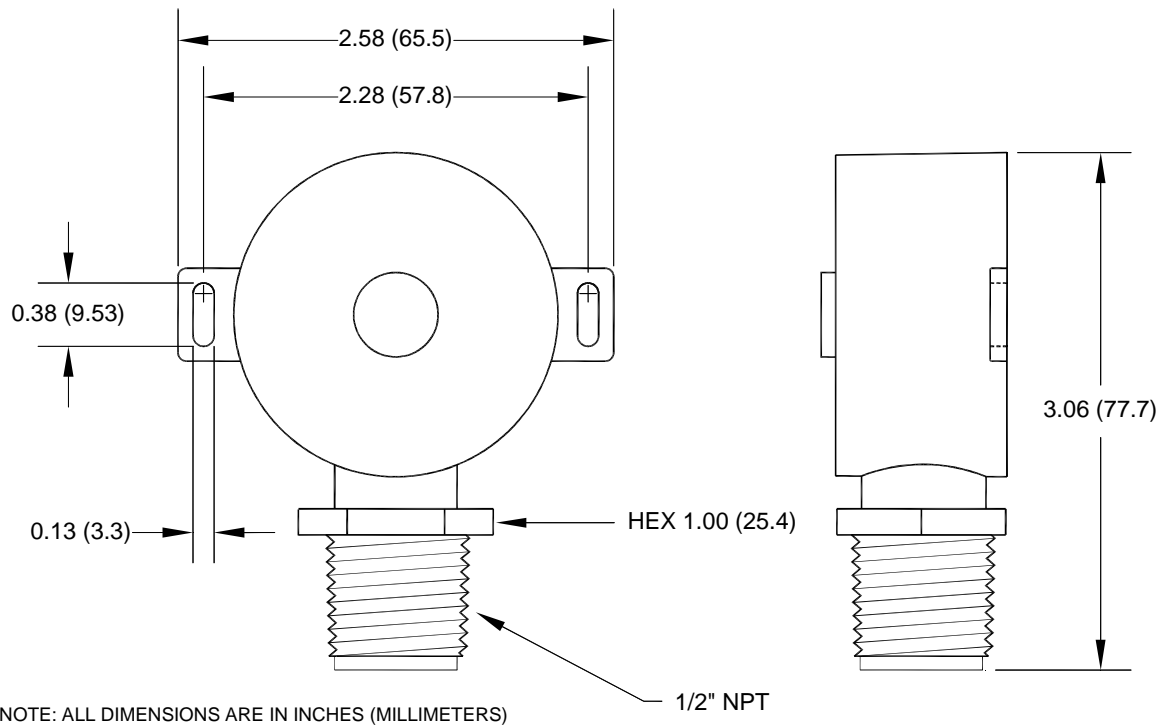
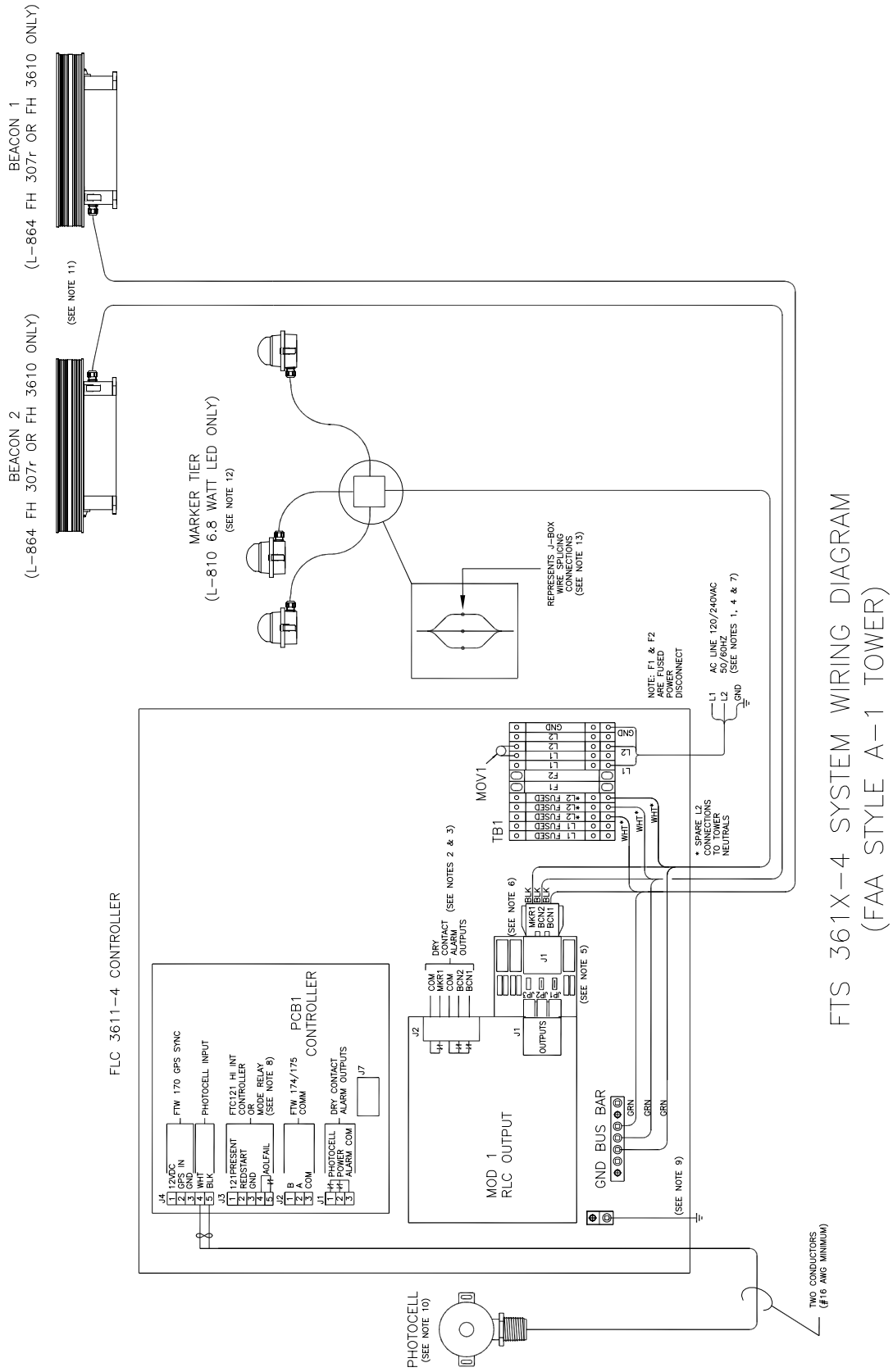

Figure 2-6 – Photocell Mounting and Outline



FTS 361X-4 SYSTEM WIRING DIAGRAM
(FAA STYLE A-1 TOWER)

Figure 2-8 – A-1 System Wiring Diagram

FLC 361X-4 CONTROLLER

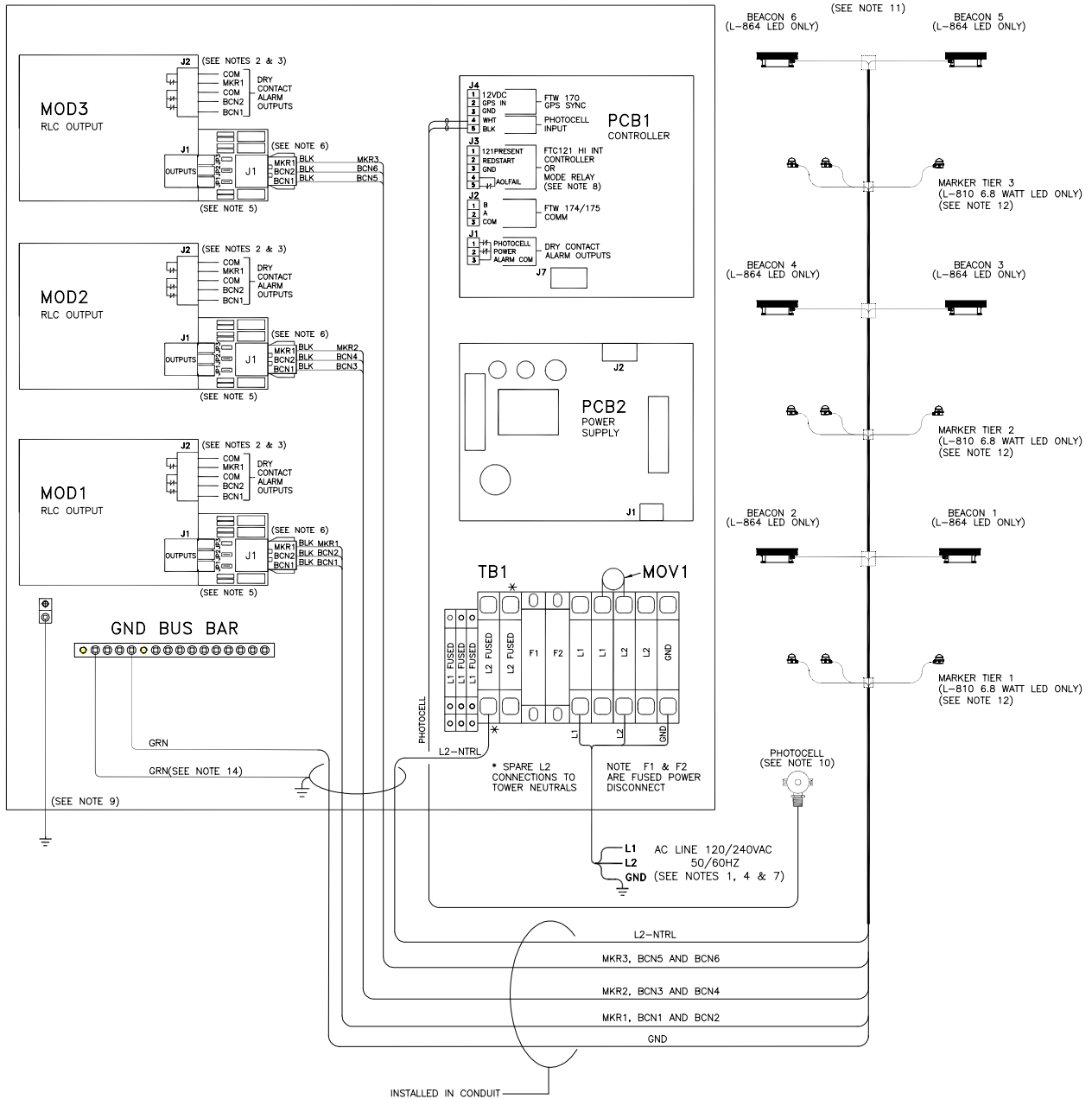

FTS 361X-4 SYSTEM WIRING DIAGRAM
(FAA STYLE A-3 TOWER)

Figure 2-9 – A-3 System Wiring Diagram

System Wiring Diagram Notes

1. AC input power conductor size depends on the service voltage, the distance from the source, the number of L-864 beacons and number of L-810 marker lights served. Use 7.8 VA per beacon plus 7.5 VA for each L-810 marker light. Also see Note 7.
2. Dry contact alarm output contact rating 5 ampere, 250 VAC. Contacts shown in normal operating state with no alarms or errors.
3. User's alarm circuit not shown.
4. The incoming AC Line Voltage (120-240 VAC 50/60Hz) is connected to the TB1 terminal strip of the FLC 361X-4 controller.
5. Only outputs connected to marker tiers should have the associated Jumper (JP1 – JP3) cut to enable the protection circuit on the MKR Surge Protector PCB.
6. Flash Technology recommends using 10 AWG as the maximum conductor size from MOD X-J1 connector. See Note 7 for information regarding the minimum required conductor size.
7. The total line drop, including the input service wiring and branch lines to the L-864 beacons and L-810 marker lights, must not exceed 3% of the rated voltage.
8. “AOLFAIL” dry contact (PCB1 J3 terminals 4 & 5) is user configured in the “CONFIG” menu. “FTC121” should only be selected if the FTS 361X-4 is interfaced with an external FTC 121 controller (Figure 2-19). Otherwise, select “MODE RLY” (Mode Relay) to allow the “AOLFAIL” dry contact to indicate the current mode of the system. When “MODE RLY” operation is selected, a closed contact indicates day mode operation and an open contact indicates night mode operation. Refer to Section 3 *Configuring the System* for additional information.
9. Ensure the grounding lug, located on the controller's back-plate, is electrically bonded to the site grounding system.
10. Mount the photocell at the top end of a vertical length of conduit. Face it toward the polar sky (north). Photocell cable should be two conductors 16 AWG minimum.
11. Lightning rods should be present for protection of the top beacon.
12. Refer to Flash Technology supplied marker kit instructions for proper J-box mounting and installation standards.
13. Mount the enclosure vertically.
14. Use NEC approved grounding method.

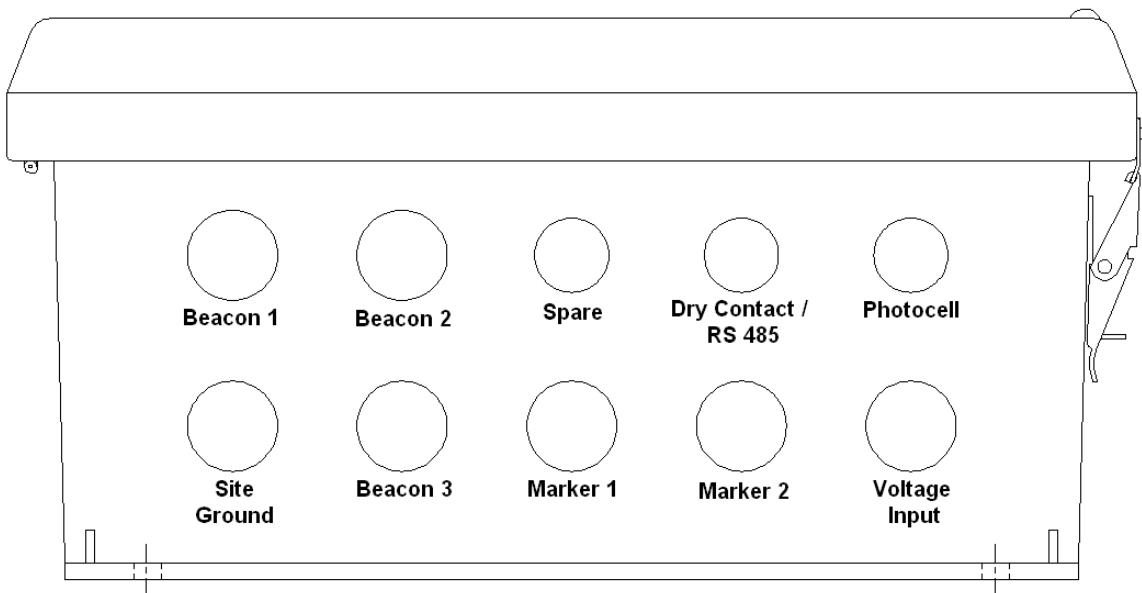

Figure 2-10 – A0 – A2 Suggested Controller Conductor Routing

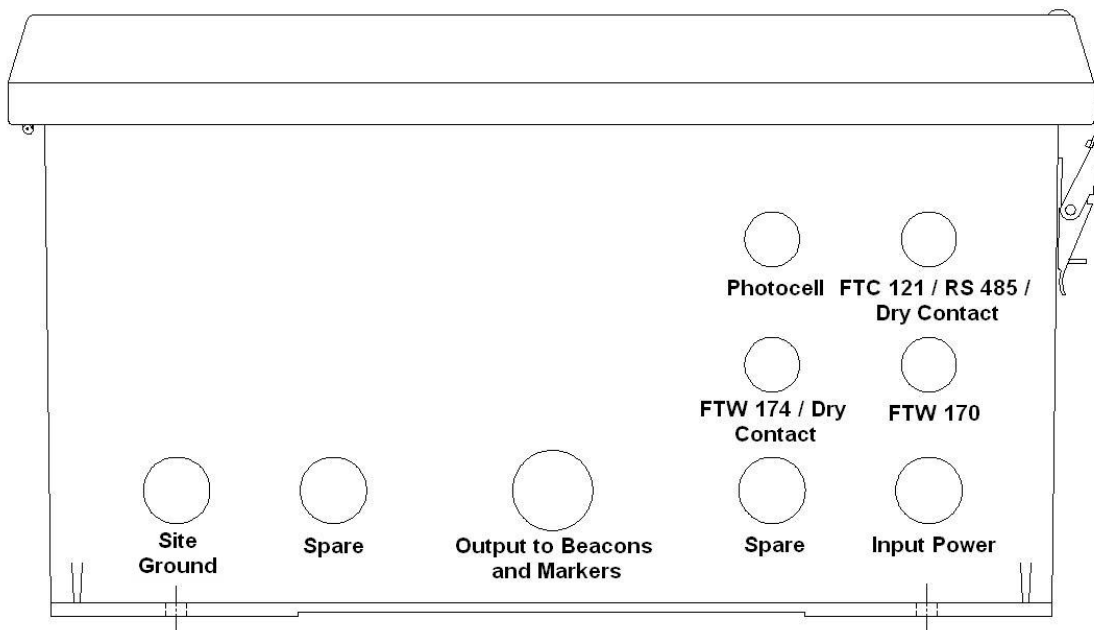
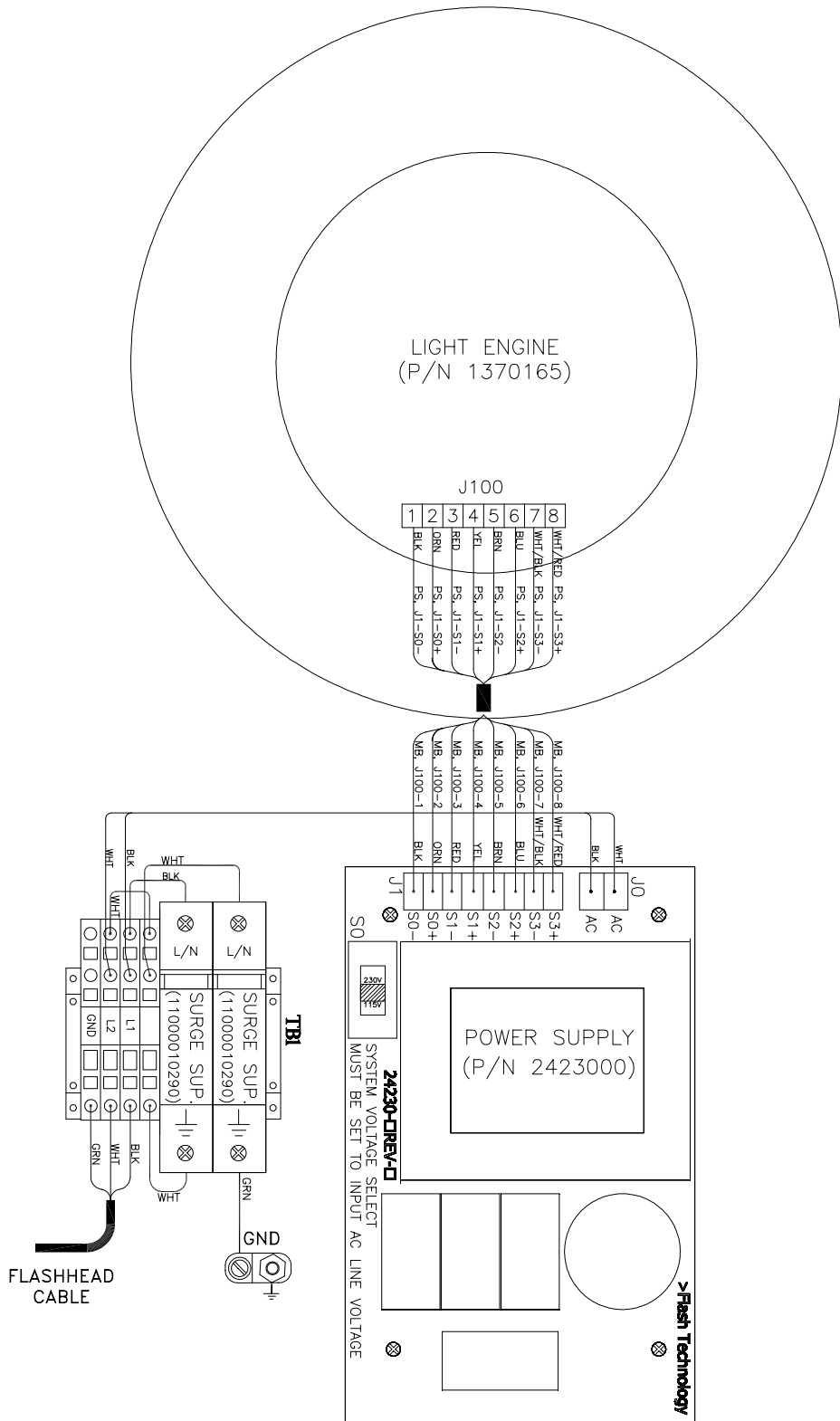

Figure 2-11 – A3 – A6 Suggested Controller Conductor Routing



FH 370R RED AC WIRING DIAGRAM

Figure 2-14 – FH 370R Internal Wiring

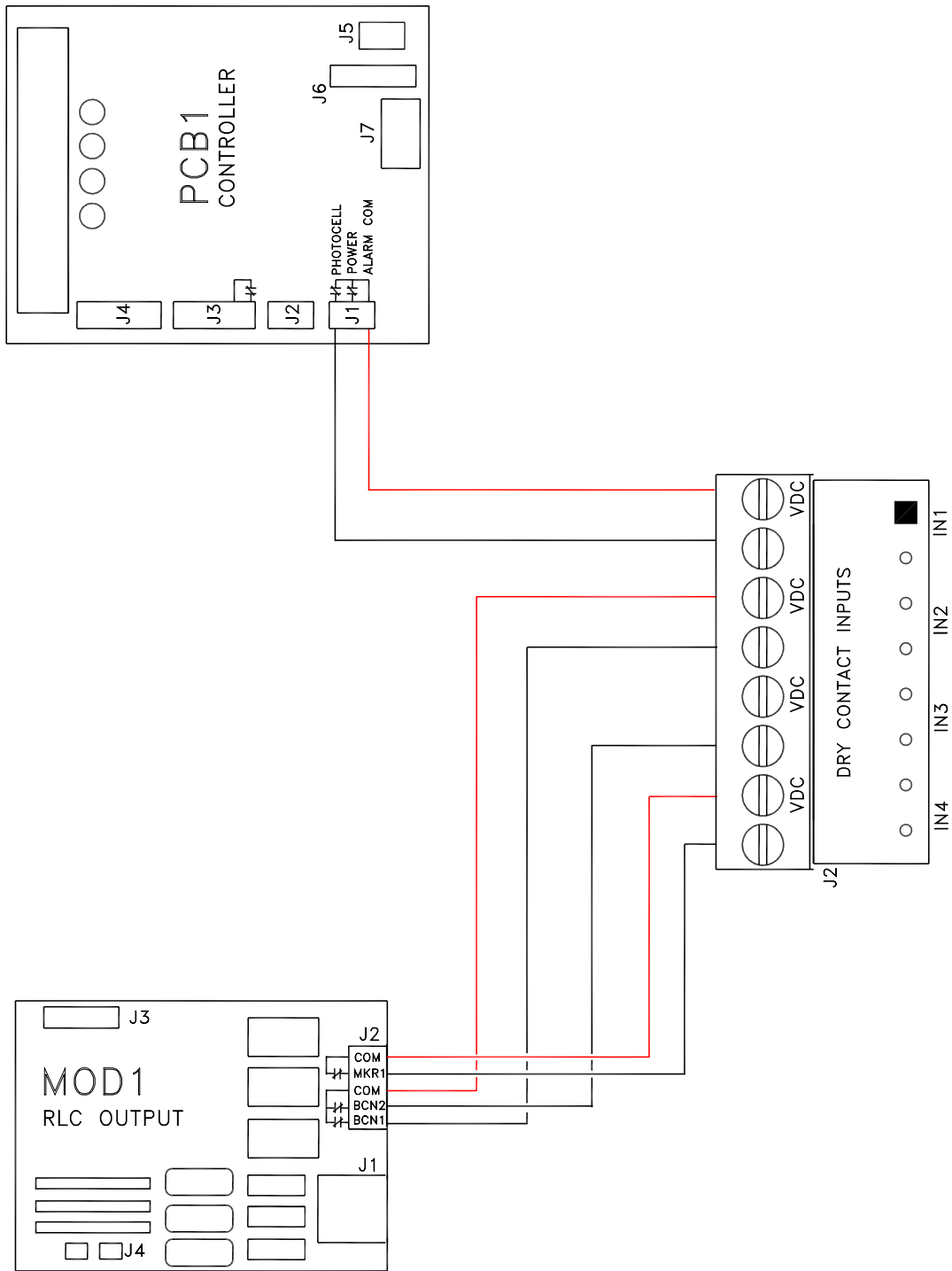

Figure 2-15 – Dry Contact Wiring Interface (Individual Alarm Points)

NOTE: J2 depicts the dry contact interface connections for a Flash Technology FTW17X series monitoring unit. Customer monitoring unit connections may vary.

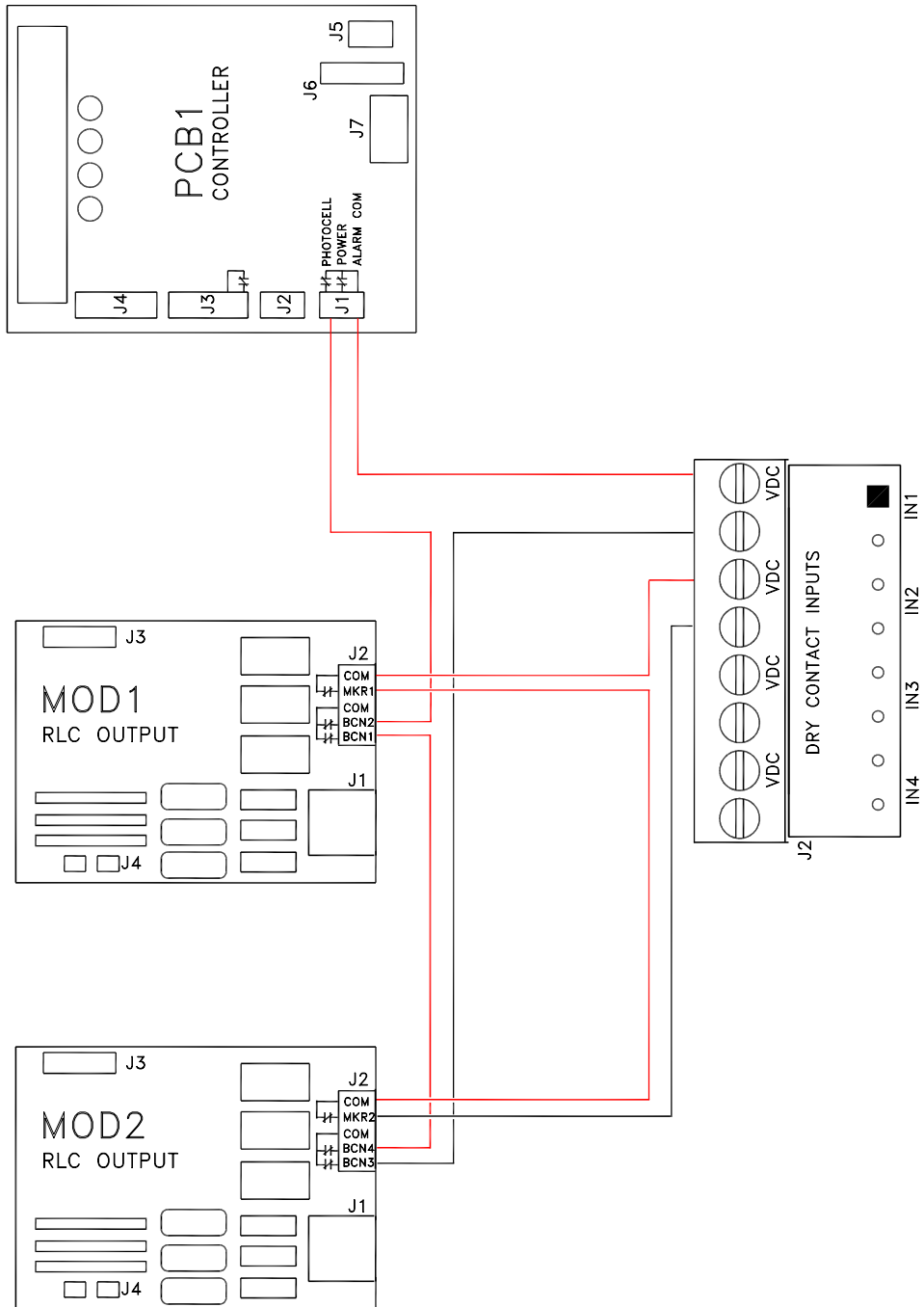

Figure 2-16 – Dry Contact Wiring Interface (Limited Alarm Points A0-A2)

NOTE: J2 depicts the dry contact interface connections for a Flash Technology FTW17X series monitoring unit. Customer monitoring unit connections may vary.

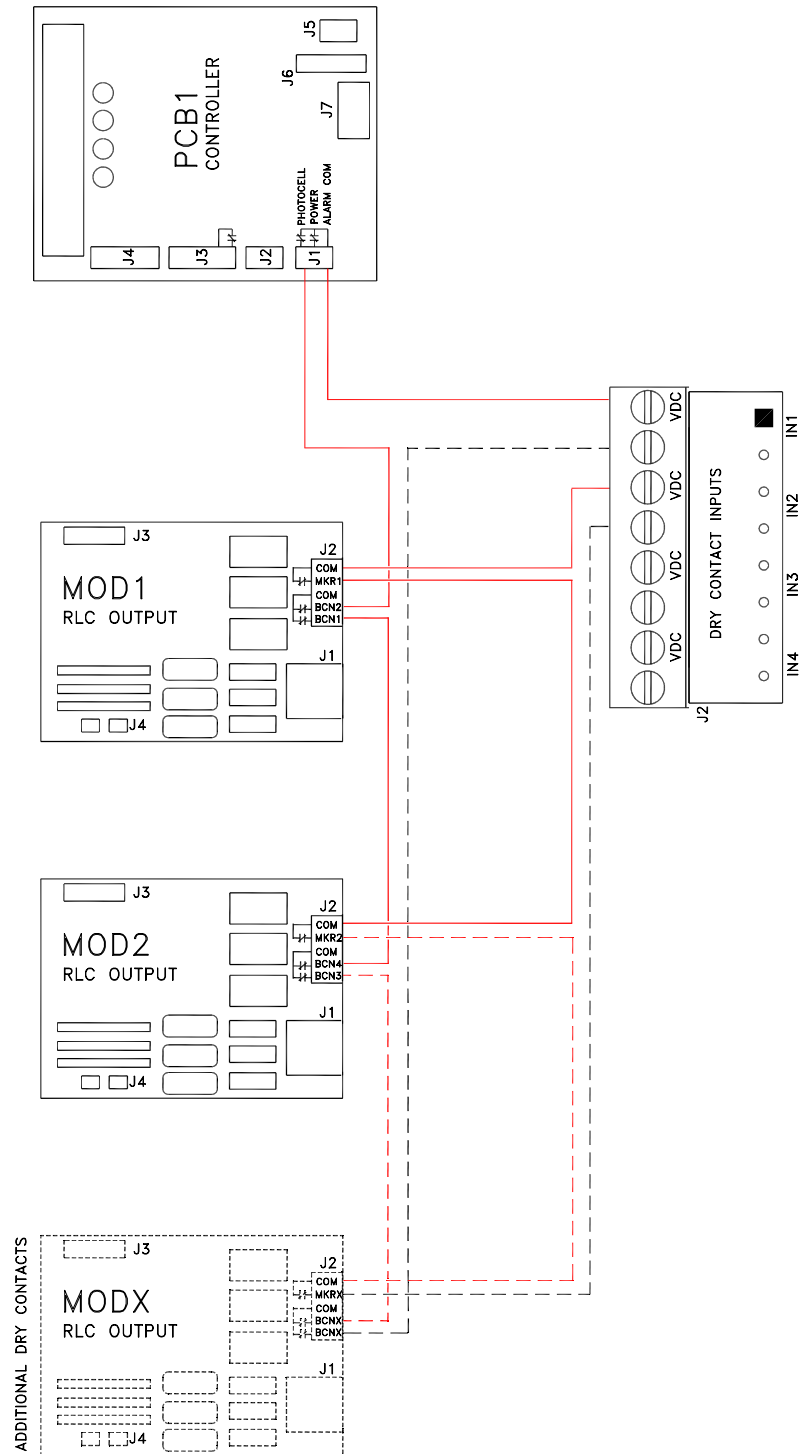

Figure 2-17 – Dry Contact Wiring Interface (Limited Alarm Points A3-A6)

NOTE: J2 depicts the dry contact interface connections for a Flash Technology FTW17X series monitoring unit. Customer monitoring unit connections may vary.

FLC 36XX-4

FTW 170

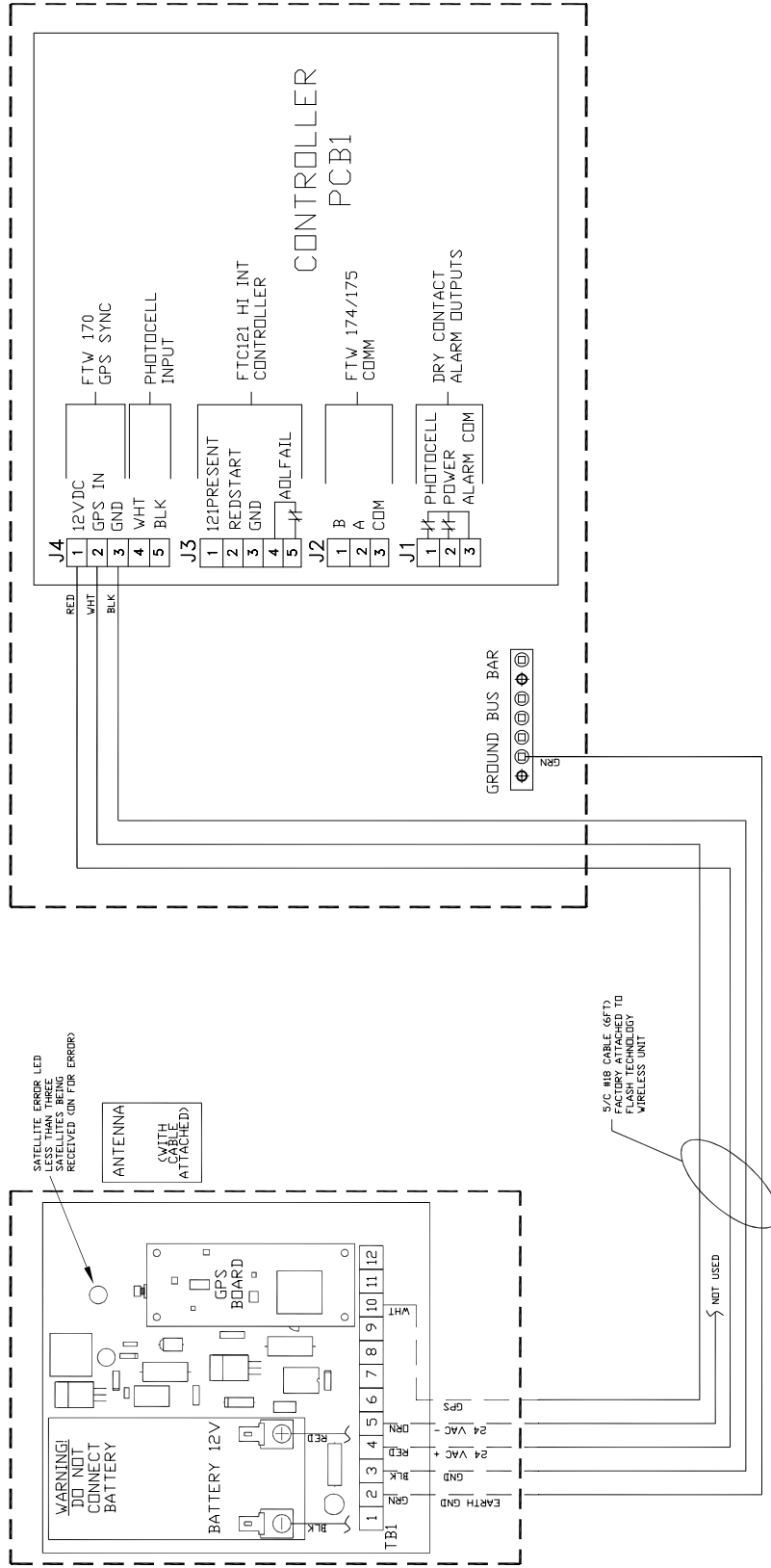

Figure 2-18 – FTW 170 Wireless GPS System Wiring Diagram

FLC 36XX-4

FTC 121

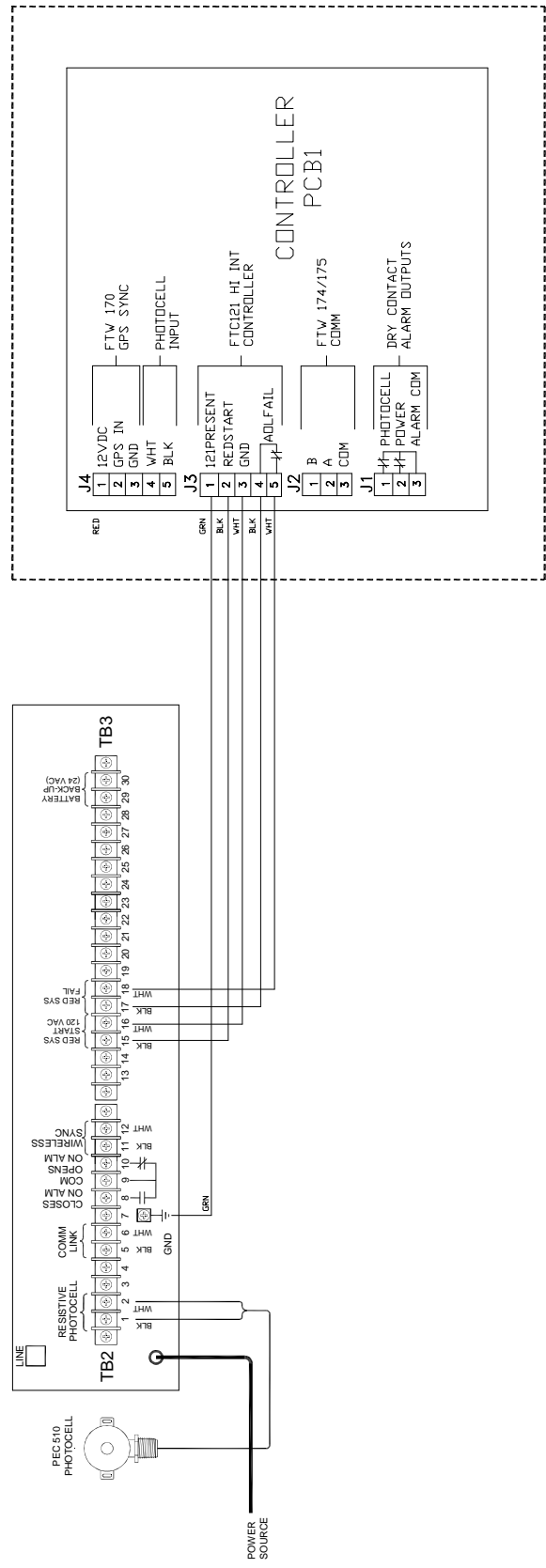

Figure 2-19 – FTC 121 System Interface

Section 3 –System Configuration and Menu Options

Menu Overview

The FLC 361X-4 controller’s menu is divided into the following three categories: Diagnostic, Configuration and Lighting Inspection. An overview of each menu category is provided in Table 3-1. Menu access is provided by the user interface described in Section 1.

To navigate to each of the top-level menu options, press the “Cancel Back” button until the display shows “Main Menu”. From the main menu, press the “OK-Next” button. The menu will show “DIAG”. Press the “Down Arrow” ↓ to advance to each of the top-level menu options. Press “OK Next” to select the desired menu option.

Table 3-1 –Top-Level Menu Options

Menu Option	Description
DIAG	Displays diagnostic data regarding the current operating status of the system.
CONFIG	User interface for programming / changing the system’s configuration including number of installed beacons and marker tiers.
LIGHTING INSPECTION	User interface for completing Quarterly and Annual Lighting Inspections manually or automatically.

Configuring the System

The FLC 361X-4 is configured at the factory. The configuration should be verified to assure that the tower has been placed in an FAA compliant status and matches the tower’s FAA determination.

System configuration will be necessary if the controller’s PCB1 board is replaced or lighting units are added to or removed from the system. The following steps describe the process of configuring the controller utilizing the information display and the user interface. The controller must be powered off and back on after changes are made to the system’s configuration.

Press the “Cancel Back” button until the display shows “Main Menu”. Press the “OK Next” button. The menu will show

“DIAG”. Press the “Down Arrow” ↓ to advance to the “CONFIG” menu. Press “OK Next” to select the option. The current system configuration will scroll across the screen. Once complete, the display will go blank awaiting input from the user interface. Press the “OK Next” button and “Type” will be displayed. Press ↑ or ↓ to advance to each of the available options which are: Red, Dual and White. Select “Red” from the menu and press “OK Next”.

The remaining configuration options are programmed in the manner described previously. The complete configuration menu is listed in Table 3-2.

Table 3-2 – Configuration Menu

Menu Option		Description
TYPE	RED	Selects the system type as RED, White or Dual. The FTS 361X system must be programmed as RED.
	DUAL	
	WHITE	
BEACONS X	0-15	Programs the total number L-864 beacons (0 - 15) connected to the controller.
MKR TIER X	0-6	Programs the total number L-810 marker tiers (0-6) connected to the controller.
PER TIER X	0-4	Programs the total number L-810 markers per tier (0-4) connected to the controller.
MKR MODE	FLASHING	Programs the marker output as flashing or steady. "FLASHING" mode will be timed to coincide with the beacon flash.
	STEADY	
PEC ALRM	ENABLED	Selects the photocell alarm as enabled or disabled. See Table 1-8 Alarm Definitions "PEC ERR" for additional information regarding the photocell alarm.
	DISABLED	
GPS SYNC	ENABLED	Selects the GPS Synchronization input as enabled or disabled. GPS Synchronization requires connection of an external FTW 170 at PCB1 J4 terminals 1, 2 & 3.
	DISABLED	
121 OPT	FTC 121	Select FTC 121 only if the FTS 361X controller is interfaced with an external FTC 121 controller. Otherwise, select "MODE RLY" (Mode Relay) to allow the "AOLFAIL" dry contact to indicate the current mode of the system. When "MODE RLY" operation is selected, a closed contact indicates day mode operation and an open contact indicates night mode operation.
	MODE RLY	
CATENARY	ENABLED	Selects Catenary operation as enabled or disabled. Catenary operation must be programmed as DISABLED.
	DISABLED	
CAT AOL	TOP BCN	CAT AOL option is available only if Catenary operation is enabled. Display of this option indicates that the FTS 361X system is programmed incorrectly. Return to "CATENARY" and select "DISABLED".
	ALL BCNS	
BCN X	TOP	BCN X option is available only if Catenary operation is enabled. Display of this option indicates that the FTS 361X system is programmed incorrectly. Return to "CATENARY" and select "DISABLED".
	MIDDLE	
	BOTTOM	
CFG DONE		Indicates that the system configuration process is complete. Review system configuration to ensure that it matches the FAA approved configuration for the structure.

NOTE: To ensure that changes to the system's configuration are saved, the FLC 361X-4 must be powered off and back on after system configuration changes are completed.

Diagnostic Menu

Table 3-3 provides a list of possible system alarms and their definitions. The diagnostic menu, presented in scrolling text format, provides information regarding the system's operational status and a more in depth description of any alarms that are listed in Table 3-3. The diagnostic menu is divided into three sections: beacons, markers, and controller. To access the Diagnostic menu,

press the "Cancel Back" button until the display shows "Main Menu". Press the "OK Next" button. The display will show "DIAG". Press the "OK Next" button again and "DIAGNOSTIC MENU" will scroll across the display followed the current system status. An overview of the system status information provided in the Diagnostic Menu is listed in Table 3-4.

Table 3-3 – Alarm Definitions

Alarm	Description
BCN(X) NITE	Indicates a beacon failure on the MOD X RLC output. The last digit(s) will change reflecting the failed beacon's number.
MKRT(X)	Indicates a marker failure on a specific tier. If multiple tiers are installed, the last digit will change reflecting the failed marker tier's number.
PEC ERR	Photocell alarm indicating that more than 19 hours have passed since the last mode change occurred via the photocell input or FTC 121 controller input.
COM ERR	Indicates a loss of communication between the controller and the MOD X RLC Output PCB's.
CFG ERR	Indicates that too many devices have been added to the system based on the configuration of the controller or the MOD X address switch has been set to the wrong position.

Table 3-4 – Diagnostic Status Menu

Menu Option	Description
MODE XXXX	MODE DAY
	MODE NIGHT
CONTROL XXXX	CONTROL AUTO
	CONTROL MANUAL
CONTROL XXXX	PHOTOCELL
	FTC 121
POWER XXXX	Displays input voltage and frequency

From the Diagnostic Status menu, press the "OK Next" button to access the Beacon, Marker and Control diagnostic menus. The status of the first lighting component, typically BCN1, will be displayed. Press to advance to each

lighting component in the system. The Control menu will be displayed after all lighting components have been displayed. An overview of each menu is provided in Tables 3-5, 3-6 and 3-7.

Table 3-5 – Beacon Diagnostic Menu

Menu Option		Description
BCN X	1-15	Displays the number of the selected beacon. Note: The Beacon Diagnostic Menu will be omitted if the system is configured for "0" beacons.
MOD X OUT X		Displays the MOD X PCB number (1-7) and output number (1-3) of the associated beacon.
ALARM /OK		Operational status of the selected beacon is displayed. See Table 3-3 Alarm Definitions for additional information.
Value	XXXXXX	Output energy is displayed as a numeric value. Note: The output value is intended for reference only and may be helpful when troubleshooting the system with Technical Support.
MOD X DATE CODE		Displays the date and time of the firmware version on the selected MOD X PCB.

Table 3-6 – Marker Diagnostic Menu

Menu Option		Description
MKRT X	1-6	Displays the number of the selected marker tier. Note: The Marker Tier Diagnostic Menu will be omitted if the system is configured for "0" Marker Tiers.
MOD X OUT X		Displays the MOD X board number (1-6) and output number (1-3) of the associated marker tier. Note: Markers should be connected to output 3 only in this application.
ALARM /OK		Operational status of the selected marker tier is displayed. See Table 3-3 Alarm Definitions for additional information.
Value	XXXXXX	Output energy is displayed as a numeric value. Note: The output value is intended for reference only and may be helpful when troubleshooting the system with Technical Support.
MOD X DATE CODE		Displays the date and time of the firmware version on the selected MOD X PCB.

Table 3-7 – Controller Diagnostic Menu

Menu Option		Description
UP TIME	XXXXXX	Displays the total time in days, hours and minutes since the last time the controller was powered on.
MODE TIME	XXXXXX	Displays the total time in hours, minutes and seconds that the controller has been in the current mode.
STATUS		Displays status and alarm codes that may be helpful when troubleshooting the system with Technical Support.
DATE CODE		Displays the date and time of the firmware version on the Controller PCB.

Lighting Inspection Menu

The Lighting Inspection menu allows all lighting components and alarm functions to be tested without physical intrusion to the controller's circuitry. The Lighting Inspection can be conducted in automatic or manual mode. Automatic mode inserts a ten second pause between alarms. No additional user interaction is required once the test is initiated. Manual mode requires the user to press the "OK NEXT" button after each function is tested before the system can advance to the next step. Manual mode is recommended when additional time is required between alarm generation and receipt of the alarm by the monitoring center.

To access the Lighting Inspection menu, press Cancel/Back until "Main Menu" is displayed. Press OK/Next once and "DIAG" will be displayed. Press **↑** to advance to the "LIGHTING INSPECTION" menu and press OK/Next. "AUTOMATIC LIGHTING INSPECTION" will scroll across the display. Press OK/Next to select this option or press **↓** to advance to "MANUAL LIGHTING INSPECTION". Table 3-7 lists the sequence of events for a typical lighting inspection. The areas shaded in light gray represent user interaction required in manual mode.

Table 3-8 – Lighting Inspection

Display	Additional info
PLACING SYSTEM IN RED NIGHT MODE	
INHIBITTING NIGHT FLASH FOR BCN 1	
BCN 1 NIGHT ALARM PRESENT	If an alarm already exists on the selected beacon, "BCN X ALREADY IN ALARM PRESS NEXT TO CONTINUE" will be displayed.
PRESS NEXT TO CONTINUE (manual mode)	
RESTORING NIGHT FLASH FOR BCN 1	
BCN1 NIGHT ALARM CLEARED	
Procedure repeats for additional beacons (if installed).	
END OF RED NIGHT BEACON TEST	
INHIBITTING MARKER T1	
MARKER T1 ALARM PRESENT	If an alarm already exists on the selected marker tier, "MKR T X ALREADY IN ALARM PRESS NEXT TO CONTINUE" will be displayed.
PRESS NEXT TO CONTINUE (manual mode)	
RESTORING MARKER T 1	
MARKER T1 ALARM CLEARED	
Procedure repeats for additional marker tiers (if installed).	
END OF MARKERS TESTS	
TESTING PHOTOCELL ALARM DRY CONTACT	If the photocell alarm is disabled, "PHOTOCELL ALARM DISABLED – SKIPPING TEST" will be displayed.
PRESS NEXT TO CONTINUE (manual mode)	
"PHOTOCELL ALARM CLEARED	If the photocell alarm test fails, "PHOTOCELL TEST FAILED" will be displayed instead.
PRESS NEXT TO CONTINUE (manual mode)	
ALL TESTS PASSED PRESS BACK	

Section 4– Maintenance and Troubleshooting

Safety

WARNING

STOP: Before proceeding read the Personnel Hazard Warning on Page ii.

Work safely, as follows:

1. Remove rings and watches before opening the equipment.
2. Shut off power to the equipment.
3. Remove the component or connect the test instruments.
4. Replace the component.
5. Turn on the power and test the system.
6. Turn off the power and disconnect the test equipment.

Preventive Maintenance

Carry out the following inspection and cleaning procedures at least once a year:

1. Verify that moisture has not entered the equipment through gaskets or seals, or collected inside as condensation.
2. Verify that all drain holes are clear.
3. Check terminal blocks and relays for corrosion or arcing. Clean or replace any component that shows evidence of high-voltage damage.
4. Check all electrical connections for tightness and verify the absence of corrosion or electrical arcing.
5. Clean the outside surface of the lens with liquid detergent and water. Wipe it gently with a soft cloth or paper towel.

Storage

Equipment should be stored indoors when not in use. Circuit boards, when not installed in the equipment, should be kept in antistatic bags or containers.

RFI Problems

The presence of radio frequency interference (RFI) can burn-out components, cause a light to flash intermittently, at the wrong rate, or intensity. RFI can enter the light by any wire to or from the unit. The circuits are designed to reject or bypass RFI, but Flash Technology cannot guarantee complete immunity beforehand. After installation, you may find it necessary to add external filters or use other methods to reduce RFI entering the equipment. To minimize interference, ensure proper installation in accordance with AC 70-7460, Appendix 1, Figure 2.

Troubleshooting

Table 4-1 provides a list of symptoms that may be observed if the system is operating incorrectly. The columns following each symptom provide the possible causes in order of probability and the corrective action.

Note: Always make resistance measurements with the primary power turned off. However, you must make voltage measurements with power applied. Thus, for your safety, carry out all preliminary steps such as connecting test leads or circuit jumpers or disconnecting existing circuit connections with the power off.

Table 4-1 – Troubleshooting

Symptom	Possible Causes	Corrective Action
System is not operating and there are no indicators lit on the PCB1 controller board.	<ol style="list-style-type: none"> 1. Input power source. 2. Fuses F1 & F2 3. MOV 	<ol style="list-style-type: none"> 1. Correct input power issues. 2. Replace F1 & F2 3. Replace MOV.
Beacons and markers are not lit. MOD X is lit.	<ol style="list-style-type: none"> 1. System setup is incorrect. 2. MKR Surge Protector PCB is not correctly seated in MOD X J1 connector. 3. J1 connections on the marker surge protector board are loose or connected incorrectly. 4. Output voltage from MOD X but no output from MKR Surge Protector PCB. 5. No output voltage from MOD X. 	<ol style="list-style-type: none"> 1. Correct programming issues with PCB 1. 2. Correct connection issues between MKR surge Protector PCB and MOD X J1. 3. Check wiring on connector J1. Verify that each connection is tight and the wire's insulation is not interfering with the connection. 4. Replace MKR Surge Protector PCB. 5. Check / replace MOD X fuses (3). Replace MOD X if the correct voltage is not observed.
Output voltage to beacon and markers is correct. MOD X is operating correctly. Beacons / markers are not operating correctly.	<ol style="list-style-type: none"> 1. Faulty wiring between controller and beacons / markers. <p data-bbox="526 1318 634 1346">FH 370r</p> <ol style="list-style-type: none"> 2. Beacon surge protectors 3. Beacon power supply. 4. Light engine failure. 	<ol style="list-style-type: none"> 1. Check output wiring from controller to connection point at beacons / markers. Pay special attention to any splice points. 2. Check / replace surge protection units. See Section 1 FH 370 for additional information. 3. Replace power supply. 4. Replace light engine.

Photocell Testing

Use the following procedure:

1. During daylight, completely block light from entering the photocell. At night, shine a light on the photocell. If the system does not transition from the current mode after a few minutes, begin the following troubleshooting steps.
2. First, disconnect the photocell from the controller. The system should go to night operation after approximately one minute.
3. If the system does not transition to night mode with the photocell disconnected, confirm 3.3 VDC is present on the photocell connections (J4 pins 4 and 5).
4. If 3.3 VDC is not present, replace PCB1.
5. If the controller changes mode correctly with the photocell removed, inspect the photocell wiring or replace the photocell. Reconnect all wires once photocell is replaced and test for proper operation.

Component Removal and Replacement

Controller

The controller component location diagram is provided in Figures 5-1 and 5-2. A controller internal wiring diagram is provided in Figures 2-12 and 2-13.

Note the location and color of all wires that you disconnect. When you replace the wiring after you replace the components, verify that the wiring agrees with Figure 2-12 (A0 – A2 system) or 2-13 (A3 – A6 system).

The general procedure for removing components is as follows:

1. Remove or relocate any component(s) that blocks access to the component in question.
2. Disconnect the wiring to the component that you want to replace.
3. Remove this component.
4. Replace everything in the reverse order: first the component, then the wiring. In some cases, you may have to place some wires on the component before you fasten it in place, then replace the remaining wires.

Most components are relatively easy to access for removal.

Beacon

Light Engine (1370165)

Remove: The Light Engine is designed to be replaced as a single assembly. Unfasten the latches on the front of the beacon's base. Lift the light engine assembly to expose the wiring harness. Disconnect the light engine from the power supply by removing the connector at J1. Disconnect the ground wire that this attached to the light engine. Lower the light engine to the closed position. Pull on the ring attached to the hinge pin and remove the hinge pin. Lift the light engine assembly to remove it from the base.

Replace: Reinstall in reverse order.

Power Supply (2423000)

Remove: Unfasten the two latches on the front of the beacon's base. Lift the light engine assembly to expose the power supply. Remove the connectors at J0 and J1. Remove the four screws that attach the power supply to the base.

Replace: Set the voltage selector switch to match the AC supply voltage. Reinstall in reverse order.

Surge Suppressor Assembly

Removal

Unfasten the two latches on the front of the beacon's base. Lift the light engine assembly to expose the surge suppressors. Disconnect the wires at the L/N and the Ground positions. Insert a flat blade screwdriver into the slot below the Ground position and push the handle toward the terminal block to release the surge suppressor assembly. To replace only the surge suppressor, pull up on the surge suppressor module to remove it from the holder.

Surge Suppressor Reinstall

Position the L/N end of the surge suppressor over the DIN rail first. Insert a flat blade screwdriver into the slot below the Ground position and push the handle toward the terminal block. Push down on the surge suppressor assembly and remove the screwdriver. Verify that the surge suppressor is firmly attached to the DIN rail. Reconnect the wires to the surge suppressor. Lower the light engine assembly to the closed position and secure both latches on the base assembly. Apply power to the beacon and verify that it operates correctly. If not, recheck all connections.

Section 5 – Recommended Spare & Replaceable Parts

Customer Service

Customer Service: 1-800-821-5825

Telephone: (615) 261-2000

Facsimile: (615) 261-2600

Shipping Address:

Flash Technology
332 Nichol Mill Lane
Franklin, TN 37067

Ordering Parts

To order spare or replacement parts, contact customer service at 1-800-821-5825.

Replaceable Parts

Table 5-1 “Controller Replacement Parts” lists the major replaceable parts for the controller.

Table 5-2 “Beacon Replacement Parts” lists the major replaceable parts for the beacon.

Table 5-3 “Optional Parts” lists optional parts for the system.

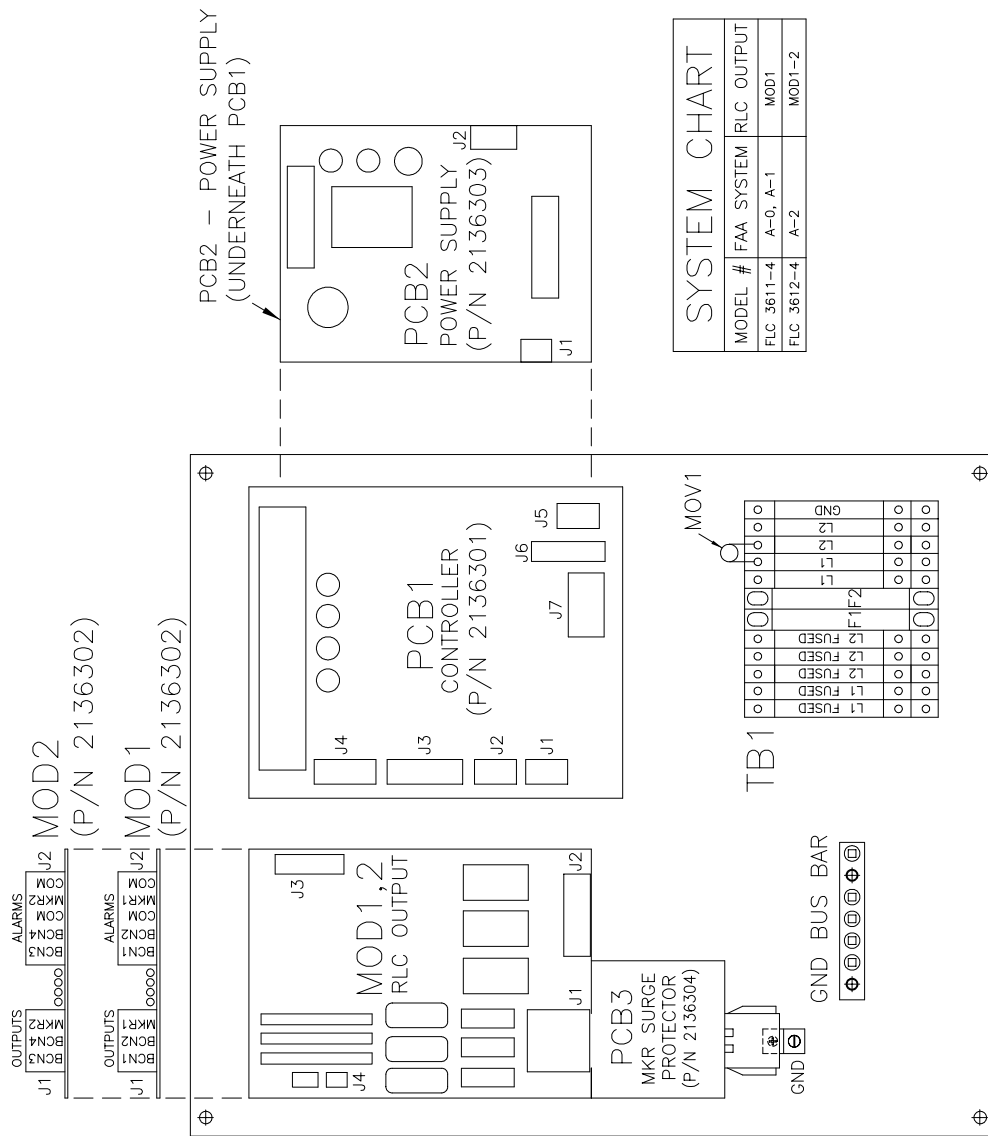

FLC 3611-4/3612-4 (120/240VAC, 50/60HZ)
 RLC - COMPONENT LOCATIONS
 (SEE SYSTEM CHART)

Figure 5-1 – A0 – A2 FLC Controller Component Locations

SYSTEM CHART			
MODEL #	FAA SYSTEM	RLC	OUTPUT
FLC 3613-4	A-3	MOD1-3	
FLC 3614-4	A-4	MOD1-4	
FLC 3615-4	A-5	MOD1-5	
FLC 3616-4	A-6	MOD1-6	
FLC 3617-4	A-6	MOD1-7	

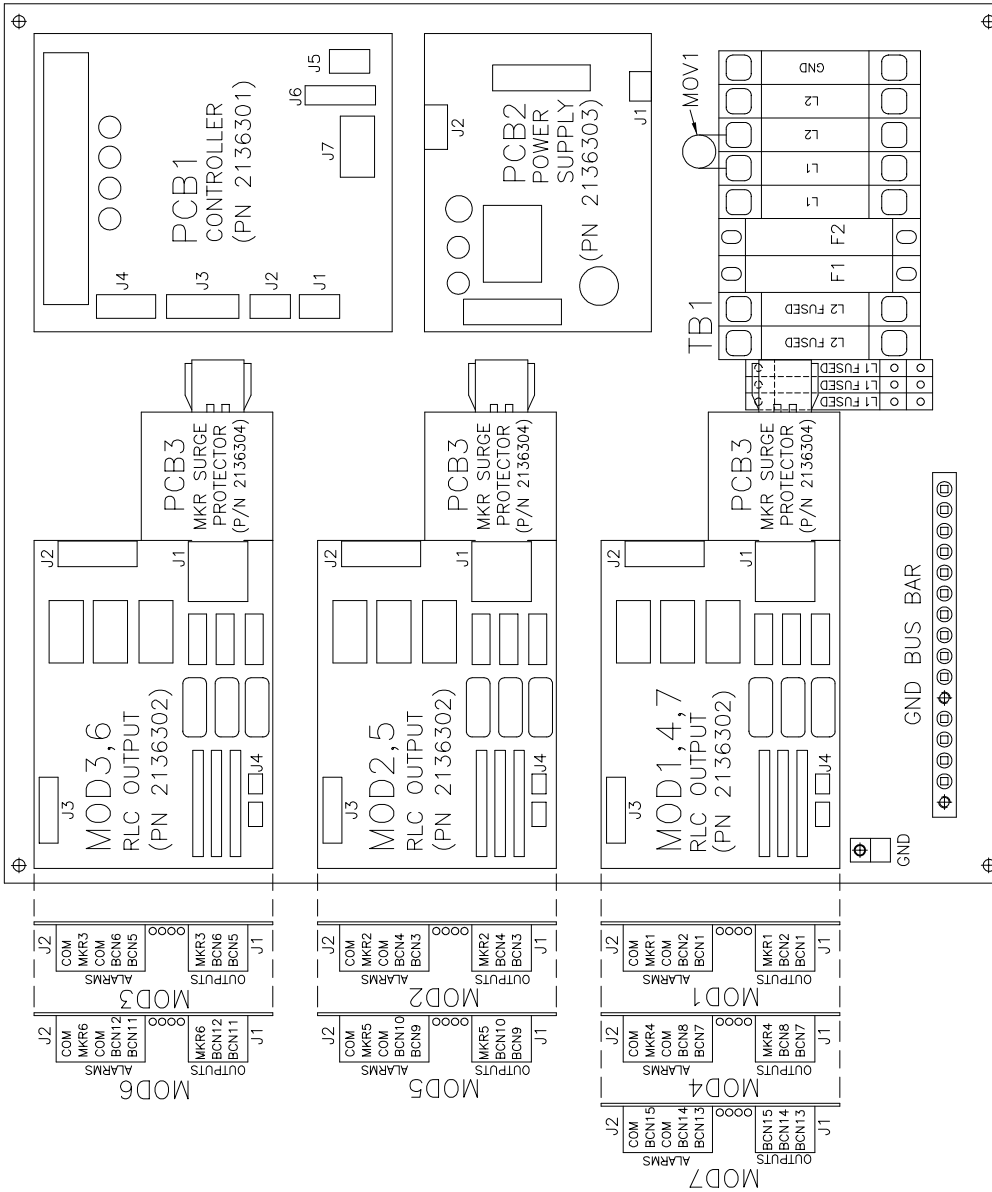

FLC 361X-4 (120/240VAC, 50/60HZ)
 RLC - COMPONENT LOCATIONS
 (SEE SYSTEM CHART)

Figure 5-2 – A3 – A6 FLC Controller Component Locations

Table 5-1 – Controller Replaceable Parts

Reference	System	Description	Part Number
PCB1	ALL	PCB CONTROLLER FLC 361X – (UNCONFIGURED)	2136301
PCB1	ALL	PCB CONTROLLER FLC 361X – (CONFIGURED)	23624(XX) *
PCB2	ALL	PCB POWER SUPPLY FLC 361X	2136303
PCB3	ALL	PCB RLC MKR SURGE PROTECTOR	2136304
MOD X	ALL	PCB RLC OUTPUT FLC 361X	2136302
MOV1	ALL	▶ VARISTOR 230/240V METAL OXIDE	6901081
F1, F2	A0-A2	▶ FUSE 8A SLO-BLO	4362041
F1, F2	A3-A6	▶ FUSE 15A SLO-BLO	4362042
MOD X FUSE	ALL	▶ FUSE 4A SLO-BLO	11000013154
TB1	A0-A2	TERMINAL BLOCK ASSEMBLY	1362027
TB1	A3-A6	TERMINAL BLOCK ASSEMBLY	1362026
-	A0-A2	CABLE FLC 361X RIBBON 2 CARD	4362044
-	A3-A6	CABLE FLC 361X RIBBON 3 CARD	4362037
-	A3-A6	CABLE FLC 361X RIBBON 7 CARD	4362038
MOD X-J1	ALL	CONN 3POS PC5/3-STCL-7.62	11000008014
FLC 361X	ALL	PEC 510 PHOTOCCELL W/20' PIGTAIL	1855001
-	ALL	SCREWDRIVER SLOT, SMALL	1362087

▶ Recommended as a Spare Part

* Part number varies according to system configuration

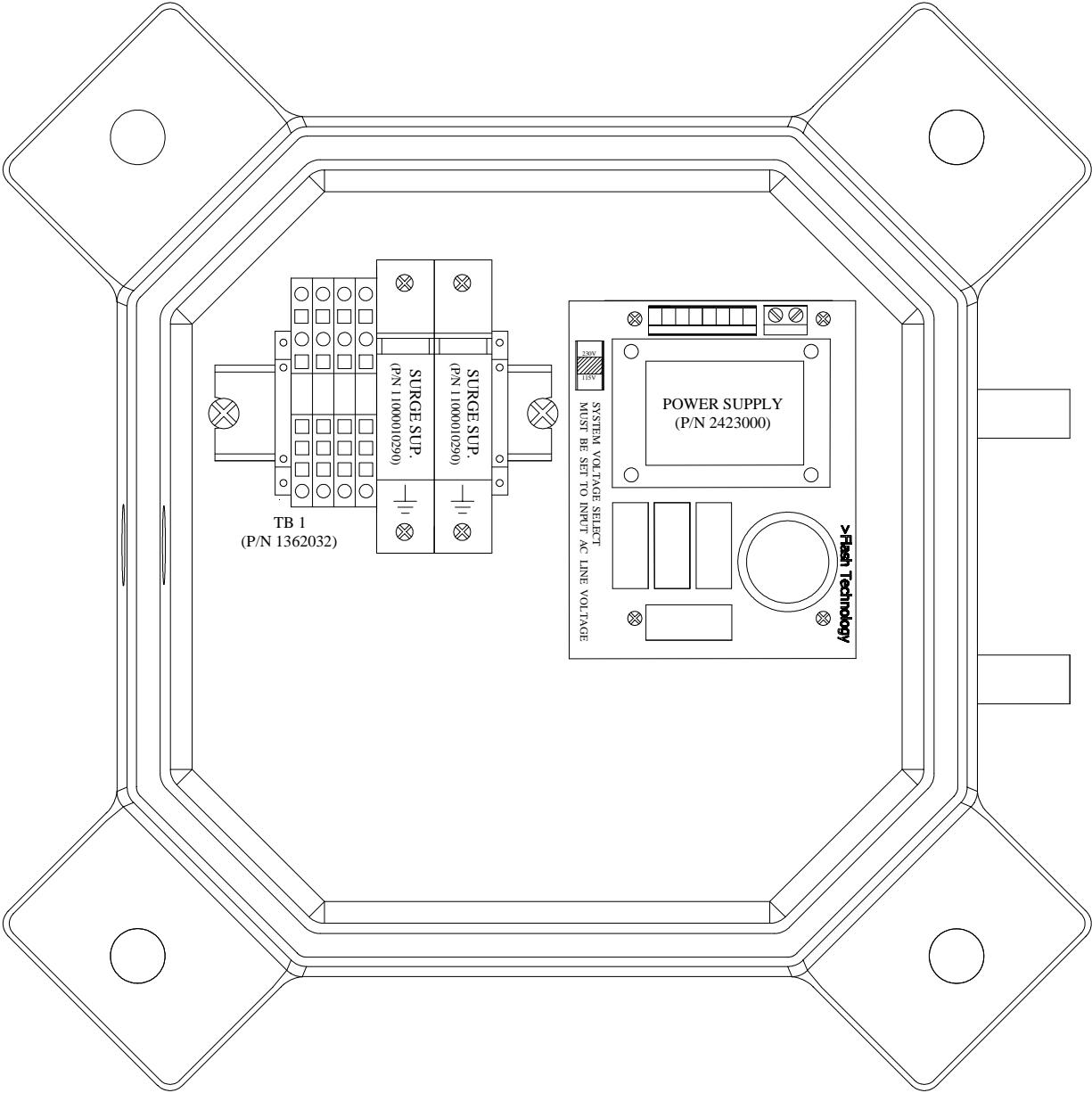

Figure 5-3 – FH 370R Component Locations

Table 5-2 – Beacon Replacement Parts

Description	Part Number
POWER SUPPLY FH 370R	2423000
SURGE SUPPRESSOR 220V 40kVA	11000010290
TERMINAL BLOCK ASSEMBLY	1362032
HINGE PIN AND LANYARD ASSEMBLY	1005303
FH 370R LIGHT ENGINE REPLACEMENT	1370165

Table 5-3 – Optional Parts

Description	Part Number
MOUNTING ADAPTER PANEL	3362047
CABLE TC-ER RATED 12AWG/3C	5991890

Return Material Authorization (RMA) Policy

IF A PRODUCT PURCHASED FROM FLASH TECHNOLOGY MUST BE RETURNED FOR ANY REASON (SUBJECT TO THE WARRANTY POLICY), PLEASE FOLLOW THE PROCEDURE BELOW:

Note: An RMA number must be requested from Flash Technology prior to shipment of any product. No returned product will be processed without an RMA number. This number will be the only reference necessary for returning and obtaining information on the product's progress.

1. To initiate an RMA: Call Flash Technology's National Operations Center (NOC) at (800-821-5825) to receive technical assistance and a Service Notification number. The following information is required before a Service Notification number can be generated:

- Site Name/Number / FCC Registration number/ Call Letters or Airport Designator
- Site Owner (provide all that apply – owner, agent or subcontractor)
- Contractor Name
- Contractor Company
- Point of Contact Information: Name, Phone Number, Email Address, Fax Number and Cell Phone (or alternate phone number)
- Product's Serial Number
- Product's Model Number or part number
- Service Notification Number (if previously given)
- Reason for call, with a full description of the reported issue

2. The Service Notification number will then serve as a precursor to receiving an RMA number if it is determined that the product or equipment should be returned. To expedite the RMA process please provide:

- Return shipping method
- Shipping Address
- Bill to Address
- Any additional information to assist in resolving the issue or problem

3. Product within the Warranty Time Period

a. If to be returned for repair;

- RMA # is generated
- Once product is received and diagnosed;
 - Covered under warranty – product is repaired or replaced
 - Not covered under warranty – quote is sent to the customer for a bench fee of **\$350 plus parts** for repair
 - If the customer does not want the product repaired, a **\$50 test fee** is charged before being returned

b. If advance replacement;

- Purchase order may be required before the advance replacement order is created
- RMA # is generated and the advance replacement order is created
- Once product is received and diagnosed;
 - Covered under warranty – credit given back if PO received
 - Not covered under warranty – credit **will not** be applied to PO
- Flash Technology has sole discretion in determining warranty claims. Flash Technology reserves the right to invoice for parts advanced if the associated failed parts are not returned within 45 days of issue or if product received is diagnosed to be non-warranty.
- Advance replacements will be shipped ground unless the customer provides alternative shipping methods.

4. Product outside the Warranty Time Period

- a. For Xenon System board repair; a purchase order is required at time of request for a RMA # for a standard **\$350 repair bench fee**
- RMA # is generated with the PO attached
 - If the board is deemed non-repairable after diagnosis, the customer is notified. If the customer purchases a new board, the repair bench fee is waived. If the customer does not buy a new board, a **\$50 test fee** is charged before being returned or scrapped.
- b. For all other products; no purchase order is required to return the product for diagnosis
- RMA # is generated
 - Once product is diagnosed, quote is sent to the customer for a bench fee of **\$350 plus parts** for repair
 - Once the purchase order is received, the product will be repaired and returned
 - If the customer does not want the product repaired, a **\$50 test fee** is charged before being returned or scrapped.

5. After receiving the Flash Technology RMA number, please adhere to the following packaging guidelines:

- All returned products should be packaged in a way to prevent damage in transit. Adequate packing should be provided taking into account the method of shipment.
- Note: Flash Technology will not be responsible for damaged items if product is not returned in appropriate packaging.**

6. All packages should clearly display the RMA number on the outside of all RMA shipping containers. RMA products (exact items and quantity) should be returned to:

Flash Technology
Attn: RMA #XXX
332 Nichol Mill Lane
Franklin, TN 37067

7. All RMA numbers:

- Are valid for 30 days. Products received after 30 days may result in extra screening and delays.
- Must have all required information provided before an RMA number is assigned.