



## **FTS 364X**

---

**LED Medium Intensity Catenary Lighting System  
Reference Manual  
Part Number 7913640**



1.

## ITEMS INCLUDED IN THIS SYSTEM

- Quick Start Guide/Manual
- Controller
- Power converter(s)
- Flashhead(s) & mounting hardware
- CAT5 communication cable(s)
- PEC w/pigtail
- Cable installation tape
- Color coded #3621 LED flashhead cable
- 1/8" Flathead screwdriver
- Optional: Universal adapter plate & hardware

## RECOMMENDED ITEMS FOR INSTALLATION

- 9" or 12" #2 flathead screwdriver
- Level
- Long-nose pliers
- Nut drivers: 1/4", 5/16", 3/8"
- Combination wrenches to include 3/4"
- Digital volt-ohm meter
- Wire strippers
- #2 Phillips® head screwdriver
- Wire ties
- Optional: 1/2" & 3/4" flex conduit & connectors

2.

## GENERAL INSTALLATION NOTES

- Power converters referred to as PC, photocell referred to as PEC, uppermost flashhead referred to as AOL.
- Controller and PC operate from a universal input power (120 or 240VAC 50/60Hz) without configuration.
- (1) 15 amp breaker is recommended for typical FAA approved LED system "D" or "E" tower types.
- Controller should be grounded with #2 Copper into the site grounding system utilizing the preinstalled grounding lug inside the enclosure.
- Incoming power connection, L2 on terminal block can also be Neutral. Refer to pages 18-21.
- Daisy chain power to other boxes
- Refer to pages a & b for installation checklist and punch-down.
- Flash Technical support available 800-821-5825 M-F, 7am -7pm CST. Monitoring support available 24/7/365.
- It is the installer's responsibility to comply with all electrical codes and the guidelines outlined in the FAA Advisory Circulars.

3.

## TYPICAL INSTALLATION

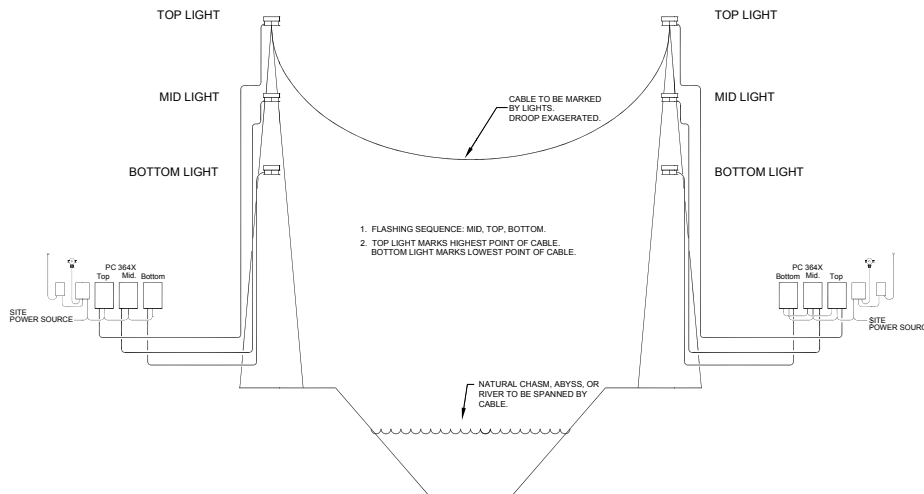

Refer to pages 33 &amp; 34 for detailed installation diagram.

4.

## COMPONENT CONNECTIONS

- Mount controller at eye-level for ease of operating Eagle 3.0 User Interface. Refer to step 7.
- Optional: A universal adapter plate is available for mounting PC, controller and/or FTW 174 to existing uni-strut. Refer to page 30 or call Flash for details.
- Resistive PEC connects to controller. Mount in upright position with unobstructed view of polar sky in accordance with FAA requirements.
- Flashhead cable(s) connects to respective PC. Utilize 1/8" flathead screwdriver provided to connect flashhead cable to terminal block at both ends.
- Connect CAT5 cable to establish communication between controller and PC(s).
- Efficient cable routing diagram is shown on page 36 for multiple systems.
- PC's may ship addressed a PC # 1. Installer must verify that each PC has a unique address assigned. Refer to page 25.
- The communications termination jumper should be shorted across both pins on the last PC in the communication chain even if there is only one PC. Refer to page 25.
- Apply power to PC and controller only after flashhead and marker cables are connected at both ends.

Refer to pages 3-11 & 34-35 for detailed controller instructions.  
And pages 12-17 & 34-35 for detailed PC instructions.

5.

## FLASHHEAD



- Utilize the 1/8" flathead screwdriver provided to connect flashhead cable to terminal block inside base of flashhead and PC.
- Refer to page 26 for proper cable termination to protect against power surges and EMI.
- Hoist flashhead via the (2) lifting/tie off holes provided on side of flashhead base.
- There should be no obstructions in horizontal path of light in accordance with FAA requirements
- Mount on level surface to ensure light output in accordance with FAA requirements.
- Ensure flashhead is electrically bonded to tower by installing on clean metal surface and utilizing stainless or galvanized hardware provided.
- Provide 5' flashhead cable service loop next to each flashhead and PC.
- Copper lighting rods should extend a minimum of 36" above top of flashhead. Beacon should be located underneath protective halo 18" horizontally from rod.

Refer to pages 26-27 detailed instructions.

6.

## CABLE



- Attach flashhead cables with special tape provided. Use of wire ties is not recommended.
- Apply tape per 2-3-4 method.
- NEC specifies tape intervals are not to exceed 5'.
- Allow 1" excess cable around tower leg flanges to avoid abrasion.
- Service loops are recommended as a precaution for future maintenance or diagnostics.
- Splicing flashhead cable is prohibited and will void the system warranty.

Refer to page 23 for detailed instructions.

7.

## EAGLE 3.0 INTERFACE



- After initial power up, interface will display the factory-set system configuration. Confirm the configuration matches the system installed.
- "Sys OK" followed by "Auto" should display next. This confirms there are no alarms detected and the PEC is set to "Auto" mode.
- Refer to pages 6-9 to run **Diagnostics**, change the system **Configuration** or perform an automated or manual **Lighting Inspection**.

Refer to pages 6-9 for detailed instructions.

8.

## MONITORING/ALARMING



- For Flash monitoring customers: Connect FTW 174 to RS485 communication located in controller. This connection is necessary for Quarterly Lighting Inspection (QLI) waiver. Refer to FTW manual for detailed interface connections.
- Dry contact alarms are configured to alarm when the state is "open". For discrete alarming, a single common connection is provided in controller and PC.
- Dry contact alarms for Power Supply and PEC are located in the controller. **Flash's 19 hour fail-safe feature is associated with the PEC contact and must be utilized to capture a mode related alarm.**
- Dry contact alarms for flashheads are located in respective PC(s).

Refer to pages 37-39 for detailed instructions.

## DUAL LED POWER CONVERTER and CONTROLLER INSTALLATION CHECKLIST

- The power converter and controller are mounted away from radio frequency interference (RFI).
- The power converter and controller are mounted upright on the Mounting Adapter Plates, water tight and lightning bonded to the site grounding system.
  - # 2 AWG wire (min.) is used to bolt the case leg of the power converter to the lightning ground system (tested for 25 ohms or less).
  - There are no holes punched or drilled in the top or sides of the enclosures.
  - Airflow can circulate around the enclosures. Allow 8 to 10" on all sides.
- The incoming service voltage and frequency ranges between 120-240 VAC 50 or 60 Hz from a 15-amp breaker with nothing else on that breaker.
- The electrical supply frequency is between 47 and 53Hz (50 cycle system) 57 and 63 Hz (60 cycle system).  
*If using a generator, 5,000 Volt Amps (5 KVA) as a minimum for a single beacon and 7,000 Volt Amps (7 KVA) as a minimum for up to 3 beacons*
- All electrical connections and inside cabinet hardware mounts have been double-checked for tightness before powering up.
  - All wire connections are installed correctly into the terminal blocks not resting on the insulation of conductors.
  - All PCB connectors are plugged in securely; wires properly inserted and screws tight in the power converter and controller.
- The power converters are connected to the correct flashhead position (top, middle & bottom).
  - The correct flashhead cable wire colors are connected to TB1 and correspond to the internal wiring.
- The photocell is connected to the **controller** at PCB 1 J4 connector pins 4 & 5.
- All **Communication Cables** are installed and routed between the controller and all PC's
- The **PCB1 JP2** termination jumper has been shorted **only** on the last power converter in the System.
- The PCB1 board's **Address Switch** in the power converter has been verified. (1,2,3 etc)
- The **PCB2 board's dipswitches** in the power converter are set for the proper Night Operation (Red or White).
- The **Intensity Select** switch (Manual Override) is in **Auto** on the **Controller**.
- The interlock switch (cover switch [white]) adjustment is OK on the power converter. *Pull switch for service (ON).*

### LED BEACON and CABLE

- LED beacon cable is **NOT** spliced.
- LED beacon cable has the outer (black) insulation jacket removed after entrance into the PC case.
  - The dome nut on the cable strain relief is tight and the LED beacon cable's mylar shield extends a ¼ inch past the body of the strain relief.
- The LED beacon cable insulation has not been nicked.
- A service loop for the LED beacon cable is placed at the base of the tower near the power converter.
- The LED beacon cable is properly secured to tower so the insulation won't become cut with wind and time.
  - Using Flash Technology's two supplied tapes and the 2-3-4-layer method, secure the cable to the tower not exceeding 5' in between.
  - A service loop is placed just below the beacon.
  - The LED beacon cable is not pulled tight against sharp edges.

The cable is secured on each side of every tower leg joint allowing 1 inch of slack around the joint.

The LED beacon is wired correctly.

The wires are positioned so no arcing can occur and wire colors match the terminal designations and the LED beacon terminal screws are tight.

The dome nut on the cable strain relief is tight and the LED beacon cable's Mylar shield extends a ¼ inch into the LED beacon cavity.

The LED beacon is securely closed with both latches in place.

The LED beacon at the top of the tower has a lightning rod(s) provided at least 36" above the top of the beacon and a minimum of 18" away from the beacon.

The LED beacon is level.

The LED beacon is grounded to the tower using the stainless steel or galvanized hardware provided.

The LED beacon is mounted in an FAA approved location (no obstruction providing a 360° view).

### **PHOTOCELL (PEC)**

The photocell mounted vertically to prevent water entry.

The PEC is mounted protected so it will not be stepped on in conduit.

The PEC is facing north and no artificial lights including security lights, street lights, lighted signs or direct sunlight will affect its operation.

### **ALARMS and ALARM WIRING**

There are NO Alarms or Intensity Error LEDs lit on the PCB boards of the controller and power converter.

The controller interface display panel is reading System OK and is displaying the correct configuration of the system installed on the structure. (White, Red or Dual with the correct number of beacons.)

Perform a diagnostic review and perform a Lighting Inspection with the User Interface Panel

***Call 1-800-821-5825 if additional TECHNICAL or INSTALLATION assistance is needed.***

## **Front Matter**

### ***Abstract***

This manual contains information and instructions for installing, operating and maintaining the FTS 364X LED Medium Intensity Catenary Lighting System.

### ***Copyright***

Copyright © 2011, Flash Technology®, Franklin, TN, 37067, U.S.A.

All rights reserved. Reproduction or use of any portion of this manual is prohibited without express written permission from Flash Technology and/or its licensor.

### ***Trademark Acknowledgements***

Flash Technology® is a registered trademark name.

ElectroFlash™, Flash Tech™, Flash Technology™, FTCA™, Flash™ and the Flash Technology Logo are all trademarks of Flash Technology.

All trademarks and product names mentioned are properties of their respective companies, and are recognized and acknowledged as such by Flash Technology.

### ***Applicable Specifications***

This equipment meets or exceeds requirements for an FAA Type L-866 and L-885.

### ***Disclaimer***

While every effort has been made to ensure that the information in this manual is complete, accurate and up-to-date, Flash Technology assumes no liability for damages resulting from any errors or omissions in this manual, or from the use of the information contained herein. Flash Technology reserves the right to revise this manual without obligation to notify any person or organization of the revision.

In no event will Flash Technology be liable for direct, indirect, special, incidental, or consequential damages arising out of the use of or the inability to use this manual.

### ***Warranty***

Flash Technology warrants all components of the LED lighting system, under normal operating conditions, for 5 years from the date of shipment from Flash Technology.

### ***Parts Replacement***

The use of parts or components, in this equipment, not manufactured or supplied by Flash Technology voids the warranty and invalidates the third party testing laboratory certification which ensures compliance with FAA Advisory Circulars 150/5345-43F, 150/5345-51, 150/5345-53C, and Engineering Brief No. 67B. The certification is valid as long as the system is maintained in accordance with FAA guidelines (FR doc. 04-13718 filed 6-16-04).

## **Personnel Hazard Warning**

### ***Dangerous Voltages***

Dangerous line voltages reside in certain locations in this equipment. Also, this equipment may generate dangerous voltages. Although Flash Technology has incorporated every practical safety precaution, exercise extreme caution at all times when you expose circuits and components, and when you operate, maintain, or service this equipment.

### ***Avoid Touching Live Circuits***

Avoid touching any component or any part of the circuitry while the equipment is operating. Do not change components or make adjustments inside the equipment with power on.

### ***Dangerous Voltages Can Persist with Power Disconnected***

Under certain conditions, dangerous voltages can be present because capacitors can retain charges even after the power has been disconnected.

Protect yourself — always turn off the input (primary) power and wait for one minute for storage capacitors to drain their charge. Then check the power converter's Capacitor PCB terminals with a voltmeter for any residual charge before touching any circuit element or component.

### ***Do Not Depend on Interlocks***

Never depend on interlocks alone to remove unsafe voltages. Always check circuits with a voltmeter. Under no circumstances remove or alter any safety interlock switch.



# Table of Contents

FTS 364X.....	i
Front Matter .....	i
Abstract .....	i
Copyright .....	i
Trademark Acknowledgements .....	i
Applicable Specifications .....	i
Disclaimer .....	i
Warranty .....	i
Parts Replacement.....	i
Personnel Hazard Warning .....	ii
Dangerous Voltages .....	ii
Avoid Touching Live Circuits .....	ii
Dangerous Voltages Can Persist with Power Disconnected.....	ii
Do Not Depend on Interlocks .....	ii
Table of Contents.....	iii
List of Figures.....	v
List of Tables .....	vi
Section 1 – Introduction and Operation .....	1
Introduction.....	1
System Overview .....	1
Specifications .....	2
Controller .....	3
PCB1 Controller Board.....	4
Diagnostic .....	7
Lighting Inspections.....	8
Configuring the System .....	9
Power Converter .....	12
Operation Overview .....	12
Micro/Filter (PCB2).....	15
Red Driver Module (MOD2) .....	15
White Driver Modules (MOD1 & MOD3).....	16
Capacitor PCB (PCB3) .....	17
AC/DC Power Supply Module (MOD4) .....	17
Section 2 – Mounting and Installation .....	18
Controller Installation .....	18
Mounting.....	18
Wiring.....	18
Power Converter Installation .....	21
Mounting.....	21
Mounting Adapter Panel (Optional) .....	21
Wiring.....	21
Flashhead Installation .....	26
Mounting.....	26
Wiring.....	26
Section 3 – Maintenance and Troubleshooting.....	43
Safety .....	43
Preventive Maintenance.....	43
Storage .....	43

RFI Problems .....	43
Component Testing.....	43
Photocell Testing .....	45
Component Removal and Replacement.....	45
Section 4 – Recommended Spare & Replaceable Parts.....	46
Customer Service .....	46
Ordering Parts .....	46
Controller Parts .....	46
Power Converter Parts .....	46
System Parts.....	46
Return Material Authorization (RMA) Policy .....	50

# List of Figures

Figure 1-1 – PCB1 Controller Board.....	4
Figure 1-2 – Controller Display and User Interface .....	6
Figure 1-3 – PCB1 Dual Interface Board .....	13
Figure 2-1 – Communication Cable.....	19
Figure 2-2 – FH Cable Install (PC).....	22
Figure 2-3 – Communication Cable Install.....	24
Figure 2-4 – PCB2 Micro/Filter SW1 Configuration .....	25
Figure 2-5 – FH Cable Connector.....	27
Figure 2-6 – FH Cable Terminal Block .....	27
Figure 2-7 – Controller Mounting and Outline.....	28
Figure 2-8 – Power Converter Mounting and Outline .....	29
Figure 2-9 – Adapter Mounting Panel Mounting and Outline (Optional) .....	30
Figure 2-10 – Flashhead Mounting and Outline .....	31
Figure 2-11 – Photocell Mounting and Outline .....	32
Figure 2-12 – Typical Catenary System Installation .....	33
Figure 2-13 – Typical Catenary System Wiring Diagram .....	34
Figure 2-14 – Suggested Controller Conductor Routing to Multiple PC's .....	36
Figure 2-15 – Suggested Power Converter Conductor Routing to Multiple PC's.....	36
Figure 2-16 – Dry Contact Alarms For FTW 174 .....	37
Figure 2-17 – Individual Dry Contact Alarms For Equipment By Others .....	38
Figure 2-18 – Limited Dry Contact Alarms For Equipment By Others .....	39
Figure 2-19 – Controller Internal Wiring.....	40
Figure 2-20 – Power Converter Internal Wiring.....	41
Figure 2-21 – FTW 170 Wireless GPS System Wiring Diagram.....	42
Figure 4-1 – FLC Controller Component Locations.....	47
Figure 4-2 – Power Converter Component Locations .....	48

## List of Tables

Table 1-1 – Physical Specifications.....	2
Table 1-2 – Performance Specifications.....	2
Table 1-3 – Status LEDES .....	5
Table 1-4 – J-Connector Interface (See Figure 1-1).....	5
Table 1-5 – Controller Display Buttons.....	6
Table 1-6 – DLC Menu Options.....	6
Table 1-7 – Alarm Definitions.....	11
Table 1-8 – Dual Interface PCB Connections.....	13
Table 1-9 – Dual Interface PCB LED’s.....	14
Table 1-10 – Dual Interface PCB Jumpers .....	14
Table 1-11 – Dual Interface PCB Address Switch .....	14
Table 1-12 – PCB1 Numeric Display .....	14
Table 1-13 – Filter PCB Connections (PCB2A).....	15
Table 1-14 – Micro PCB Connections (PCB2B).....	15
Table 1-15 – Micro PCB LED’s (PCB2B).....	15
Table 1-16 – Red Driver Module Connections.....	15
Table 1-17 – Red Driver Module LED’s .....	15
Table 1-18 – White Driver Module Connections .....	16
Table 1-19 – White Driver Module LED’s.....	16
Table 1-20 – Capacitor PCB Connections .....	17
Table 1-21 – Capacitor PCB LED’s .....	17
Table 1-22 – AC/DC Power Supply Module Connections.....	17
Table 3-1 – Troubleshooting.....	44
Table 4-1 – Controller Replacement Parts.....	47
Table 4-2 – Power Converter Replacement Parts.....	48
Table 4-3 – System Replacement Parts .....	49

This page intentionally left blank.



# Section 1 – Introduction and Operation

## Introduction

The FTS 364X is an LED Medium Intensity Catenary Lighting System. The system can be configured for L-866 (white), L-885 (red), or L-866/L-885 (dual) applications.

Catenary lighting systems require three levels (tiers) of lights. One tier of lighting is installed at the top of the structure. One tier is installed at the lowest point of the catenary. One tier is installed half way between the upper and lower levels. Each level must be lit to provide 360-degree coverage. The flash rate is 60 flashes per minute in all modes and follows the pattern: middle – top – bottom.

## System Overview

The FTS 364X series LED Lighting Systems have been designed for long life, reducing the need for service. In the event that service is required, the need for climbing is reduced by locating all drive and control electronics on the ground. Ease of installation and service is enhanced by simple wiring, setup, and diagnostics. Increased safety is provided with operating voltages of less than 200VDC.

Each Lighting System consists of one controller and three or more flashheads and its associated power converter. Each flashhead requires its own power converter.

The light source for the flashhead is comprised of Light Emitting Diodes (LEDS). All drive and control electronics are located in the power converter which may be located on the ground (up to 550 ft flashhead cable length), minimizing the need for climbing during maintenance cycles or for repair. The power converter provides controlled drive currents to the flashhead for proper light output.

The controller provides overall system control including mode control, synchronization of multiple power converters, and alarm collection and notification. Communication between the controller and power converters is via RS-485, providing robust and highly reliable communication. Both the controller and power converters operate between the ranges of 120-240 VAC 50/60 Hz with no modifications necessary to the input power modules. The FTS 364X series systems are not phase sensitive relative to the input power. Any circuit breaker in the electrical distribution panel may be utilized on each power converter or controller.

This manual provides guidance and recommendations for the installation, operation, and troubleshooting of the lighting system. Please read this document in its entirety before installation.

## Specifications

Table 1-1 – Physical Specifications

Parameter	
FLC 3640 Controller Dimensions (H x W x D) Weight	15.32 x 12.76 x 6.60 in 12 lbs
PC 3640 Power Converter Dimensions (H x W x D) Weight	23.00 x 17.13 x 6.44 in 42 lbs
FH 3640Flashhead Dimensions (H x DIA) Weight	7.06 x 17.0 in 28 lbs
PEC 510 Photocell (H x W x Depth)	3.06 x 2.58 x 1.02 in

Table 1-2 – Performance Specifications

Parameter	
Application Flash Intensity (nominal) Day (White) Night (Red) Night (White), White Backup	L-866 and L-885  20,000 ± 25% ECD 2,000 ± 25% ECD 2,000 ± 25% ECD
Flash Rate Day (White) Night (Red) Night (White)	60 flashes per min. 60 flashes per min. 60 flashes per min.
Primary Power	120-240VAC, 50/60 Hz
Power Consumption	White Day 120 W Red Night 45 W White Night 20 W
Environmental	Complies with FAA specifications in AC 150/5345-43F.
Flashhead cable length	15 - 550 ft.



## **Controller**

### **Operation Overview**

The controller component layout is shown in Figure 4-1 and wiring diagram in Figure 2-19.

The incoming AC Line (120-240 VAC 50/60Hz) is connected to terminal strip TB1. Mounted on TB1 is a Metal Oxide Varistor (MOV1) which reduces line surges and transients. Input power fuses F1 and F2 are also mounted on TB1. Disconnect power from the controller before servicing the fuses or MOV. Fuse holders are hinged on the upper side. Lift and open side cover to access the fuse.

The Power Supply (PCB2) converts AC input power to 12VDC for the controller PCB (PCB1).

The controller PCB (PCB1) supervises system operation. A User Interface with alphanumeric display and pushbuttons provides system configuration and alarm notification.



## PCB1 Controller Board

PCB1 controls and monitors the operation of the FLC 3640 controller and the PC 364X power converter. Status indicators and setup options are shown below.

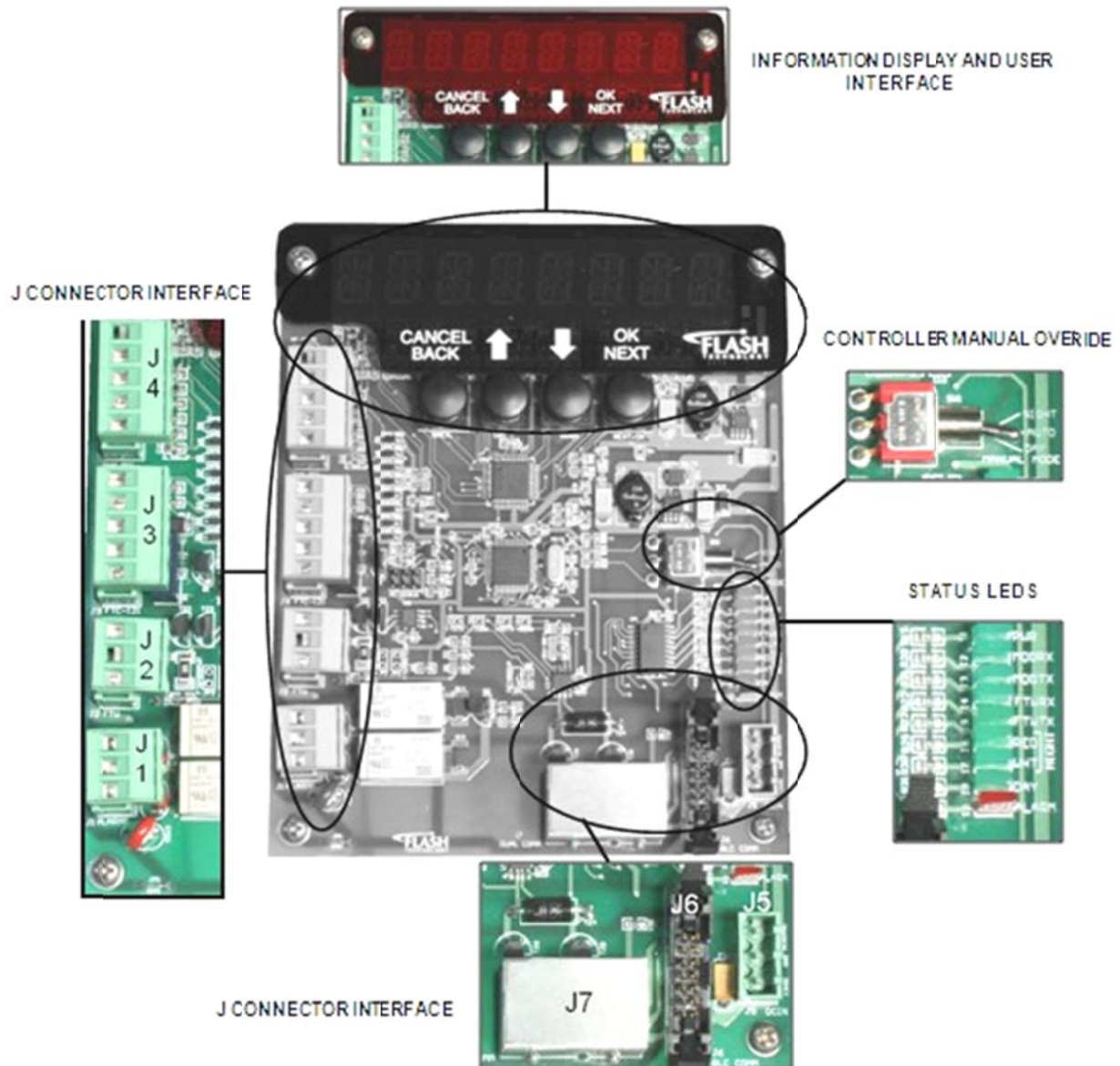

Figure 1-1 – PCB1 Controller Board



## Controller PCB1 Information Display and User Interface



Figure 1-2 – Controller Display and User Interface

There is an 8 character display on the system controller board. It defaults to a display of the status of the system. The main screen will read “AUTO” or “MANUAL” (depending on the status of the controller manual override switch) and “SYS OK”. Active alarm conditions will replace “SYS OK” if present. See Table 1-7 for a list of alarms and definitions. The following depicts the configured display of a typical catenary system: “AUTO – SYS OK – CURRENT CONFIG TYPE DUAL – PEC ALARM

ENABLED – BEACONS 3 – MKR TIERS 0 – MKR/TIER 0 – MKR MODE STEADY – CATENARY CFG – BCN1 TOP – BCN2 MID – BCN3 BOT”. The display text can be stationary or in scrolling format.

Note: Pressing the “Cancel / Back” button will return the controller to the previous menu level. Pressing the “Cancel / Back” button at the main menu level will reset the main menu display and return to “SYS OK” or “ALARMS”.

Table 1-5 – Controller Display Buttons

Button	Function
CANCEL / BACK	Returns BACK to a previous screen or CANCELS a previous command
UP ▲	Navigates UP through the active menu options
DOWN ▼	Navigates DOWN through the active menu options
OK / NEXT	OK Confirms your selection or Advance to the NEXT option

Table 1-6 – DLC Menu Options

Menu Option	Description
DIAG	Displays diagnostic data on the current operating status of the system
LIGHTING INSPECTION	User Interface for completing Manual or Automatic Lighting Inspections
CONFIG	User interface for programming the controller to the existing system configuration

## Diagnostic

The Diagnostic menu provides valuable data detailing the system operation status and a more in depth description of alarms that may be active. The information is displayed in scrolling text format. The

diagnostic menu is broken down into two sections, power converter and controller. The steps below describe the procedure utilizing the controller display and user interface.

- From the Main Screen push the OK/NEXT button and “DIAG” will display
- Press OK/NEXT button again to enter the Diagnostic Menu.
- Example of displayed data will read “ DIAGNOSTIC MENU – MODE RED NITE – CONTROL AUTO – CONTROL PHOTOCELL – POWER 110-120V 60HZ”
  - MODE RED NITE = Indicates the current operating mode the system is in
  - CONTROL AUTO = Indicates the system mode switch is in Auto position
  - CONTROL PHOTOCELL = Indicates mode is transitioned with the photocell
  - CONTROL MANUAL = Indicates the mode switch is placed in the day or night position.
  - POWER 110-120V 60HZ = Indicates the incoming power supply information that is operating the controller.
- Press the OK/NEXT button to review the diagnostics on the power converter.
- Example of displayed data will read “ BCN1 PC1- WHT MOD1 GOOD- WHT MOD3 GOOD- RED MOD2 GOOD- NO ALARM –PC1 DATE CODE – JAN 6 2011 – 09 42 15”
  - BCN1 PC1= Indicates which power converter board is being diagnosed
  - “WHT MOD1 GOOD” Indicates that the white LED strings powered by MOD 1 are operating without failures.
  - “WHT MOD3 GOOD” Indicates that the white LED strings powered by MOD 3 are operating without failures.
  - “RED MOD2 GOOD” Indicates that the red string of LEDs powered by MOD 2 is operating without failures.
  - NO ALARMS = There are no present failures detected on the power converter.
  - JAN 6 2011 – 09 42 15 = Indicates the date and time of the latest Firmware Revision of the power converter board in hours, minutes and seconds format.
- Press the UP ▲ button to review the diagnostics for any additional power converters or to proceed to the diagnostics on the PCB1 controller board.
- Example of displayed data on the PCB1 controller board will read “ CONTROL – UP TIME – 123 13 45 – MODE TIME – 08 15 30 – STATUS 00000000 – ALA MASK 00000000 – JAN 6 2011 – 09 42 15”
  - CONTROL = Indicates the diagnostics are displaying for the controller.
  - UP TIME – 123 13 45 = Indicates the amount of time that has elapsed since power cycling of the controller in days, hours and minutes format.
  - MODE TIME – 08 15 30 = Indicates the duration the controller has been in the present mode in hours, minutes and seconds format.
  - STATUS 00000000 and ALA MASK 00000000 = Indicate diagnostic Alarm Codes that can be useful for interfacing with Flash Technology Technical Support staff to provide a more detailed description of the faults that are occurring with the system.
  - JAN 6 2011 – 09 42 15 = Indicates the date and time of the latest Firmware Revision of the controller PCB1 board in hours, minutes and seconds format.

## Lighting Inspections

The FLC 3640 Lighting Inspection feature allows the user to interface with the complete Lighting System on the structure without any physical intrusion to the circuits in the controller or the power converter. The Lighting Inspection feature

is available to run in an Automatic mode or in a Manual step by step progressive approach. The steps below describe the procedure utilizing the controller display and user interface.

- From the Main Screen push the OK/NEXT button and “DIAG” will display
- Scroll through the options using the UP ▲ or DOWN ▼ button until “LIGHTING INSPECTION” is displayed. Press OK/NEXT button.
- “AUTOMATIC” is displayed press the OK/NEXT button if this option is desired. If “MANUAL” inspection is desired press the UP ▲ button and then press the OK/NEXT button to proceed.

### **MANUAL INSPECTION TESTING:**

- “PLACING SYSTEM IN DAY MODE PLEASE WAIT – INHIBITTING DAY FLASH FOR BCN1 – BCN1 DAY ALARM PRESENT” will scroll. The alarm for beacon 1 is now active on the controller. Press the OK/NEXT button when you are ready to restore the alarm.
- “RESTORING DAY FLASH FOR BCN1 – BCN1 DAY ALARM CLEARED” This should clear the alarm unless there was an actual alarm present on the system. Press the OK/NEXT button to proceed to the other beacons if present on the system. Repeat the above steps until you have engaged all beacons in the system.
- “END OF DAY BEACON TEST” will scroll when all beacons have been tested. Then the above process is repeated by the controller automatically placing the system in white night mode and testing each beacon.
- “PLACING SYSTEM IN WHT NIGHT MODE PLEASE WAIT – INHIBITTING WHT NIGHT FLASH FOR BCN1 – BCN1 NIGHT ALARM PRESENT” will scroll. The alarm for beacon 1 is now active on the controller. Press the OK/NEXT button when you are ready to restore the alarm.
- “RESTORING WHT NIGHT FLASH FOR BCN1 – BCN1 NIGHT ALARM CLEARED” This should clear the alarm unless there was an actual alarm present on the system. Press the OK/NEXT button to proceed to the other beacons if present on the system. Repeat the above steps until you have engaged all beacons in the system.
- “END OF WHT NIGHT BEACON TESTS” will scroll when all beacons have been tested. Then the above process is repeated by the controller automatically placing the system in red night mode and testing each beacon.
- “PLACING SYSTEM IN RED NIGHT MODE PLEASE WAIT – INHIBITTING RED NIGHT FLASH FOR BCN1 – BCN1 NIGHT ALARM PRESENT” will scroll. The alarm for beacon 1 is now active on the controller. Press the OK/NEXT button when you are ready to restore the alarm.
- “RESTORING RED NIGHT FLASH FOR BCN1 – BCN1 NIGHT ALARM CLEARED” This should clear the alarm unless there was an actual alarm present on the system. Press the OK/NEXT button to proceed to the other beacons if present on the system. Repeat the above steps until you have engaged all beacons in the system.
- “END OF RED NIGHT BEACON TESTS” will scroll when all beacons have been tested.

- If the photocell alarm is enabled, “TESTING PHOTOCELL ALARM DRY CONTACT” will be displayed and the photocell alarm dry contact will be tested. If it is not enabled, “PHOTOCELL ALARM DISABLED – SKIPPING TEST” will be displayed. The test results will be displayed as “PHOTOCELL TEST FAILED” or “PHOTOCELL ALARM CLEARED”.
- Press CANCEL/BACK button to end the Lighting Inspection.

#### **AUTOMATIC INSPECTION TESTING:**

- If using the AUTOMATIC LIGHTING INSPECTION option it will display exactly as the MANUAL LIGHTING INSPECTION feature without the need for interaction from the user. It will progress through every beacon and provide you with an “ALL TESTS PASSED – PRESS BACK” after completion. Using the Auto feature provides a 10 second delay between each alarm. If this is not enough time for alarm receipt by your monitoring company then the Manual feature should be utilized.

### **Configuring the System**

The FLC 3640 configuration is preset from the factory. Configuring the system will only be necessary if the controller PCB1 board ever needs replacing or other power converters are added to the existing system. The configuration steps below describe the process utilizing the controller display and user interface. The power

converter’s Micro/Filter PCB2 SW1 configuration (Figure 2-4) and the Addressing Rotary switch selection should be confirmed before proceeding with configuration of the controller. Always power cycle the controller after any changes if the configuration has to be adjusted.

- From the Main Screen push the OK/NEXT button and “DIAG” will display
- Scroll through the options using the DOWN ▼ button until “CONFIG” is displayed.
- Press OK/NEXT
- The current configuration will be displayed. To change, press OK/NEXT button.
- “TYPE DUAL, WHITE or RED will be displayed depending on present configuration.
- Press the DOWN ▼ button until the correct system type is displayed and press OK/NEXT button
- “BEACONS” will flash followed by a number (The number designates the number of beacons the controller should be monitoring) Press UP ▲ or DOWN ▼ until the desired number of beacons is displayed and press OK/NEXT.
- “MKR TIER” will flash followed by a number. Press DOWN ▼ until “0” is displayed and press OK/NEXT.\* (The number designates the number of marker tiers the controller should be monitoring – “0” should be selected for Catenary systems.)
- “PER TIER” will flash followed by a number. Press DOWN ▼ until “0” is displayed and press OK/NEXT.\* (The number designates the number of markers per tier the controller should be monitoring – “0” should be selected for Catenary systems.)
- “MKR MODE” will flash followed by “FLASHING” or “STEADY”. Press DOWN ▼ until “STEADY” is displayed and press OK/NEXT.\*
- “PEC ALRM” Will flash followed by “ENABLED” or “DISABLED”. Press UP ▲ or DOWN ▼ until the desired setting is displayed and press OK/NEXT.

- “GPS SYNC” Will flash followed by “ENABLED” or “DISABLED”. Press UP ▲ or DOWN ▼ until the desired setting is displayed and press OK/NEXT.
- “CATENARY” Will flash followed by “ENABLED” or “DISABLED”. Press UP ▲ or DOWN ▼ until the desired setting is displayed and press OK/NEXT.
- “CAT AOL” Will flash followed by “TOP BCN” or “ALL BCN”. Press UP ▲ or DOWN ▼ until the desired setting is displayed and press OK/NEXT. \*\* (The “ALL BCN” setting is recommended for Dual L-866/885 applications.)
- “BCN 1” Will flash followed by “TOP”, “MIDDLE” or “BOTTOM”. Press UP ▲ or DOWN ▼ until the desired setting is displayed and press OK/NEXT. Repeat for each beacon installed in the system. \*\*
- “CFG DONE” will flash followed by the text “HIT BACK” prompting the user to return to the Main Screen. Press the Cancel/Back button.

**\* L-810 side markers are typically not installed with Catenary systems.**

**\*\* This step is available only if “Catenary” mode is “Enabled”.**



Table 1-7 – Alarm Definitions

Alarm	Description
PC(X) NITE	Indicates a night beacon failure on a slave power converter. The last digit will change reflecting the failed power converter.
PC(X) AOL / PC1 NITE	Indicates a night beacon failure on the designated AOL (Uppermost) beacon and the system is in low intensity white night
MKRT(X)	Indicates a marker failure on a specific tier. If multiple tiers are installed the last digit will change to that designated tier number. L-810 side markers are typically not installed with Catenary systems. This alarm will normally indicate a configuration error in a Catenary system.
PC(X) DAY	Indicates a day beacon failure on a slave power converter. The last digit will change reflecting the failed power converter.
PEC ERR	Indicates an alarm on the photocell. The system has failed to change modes within 19 hours through the photocell transition process.
PC(X) MODE	Indicates the power converter is not in the same mode as the controller.
PC(X) CFG	Indicates the configuration in the power converter does not match the configuration that was programmed into the controller
PC(X) DIM	Indicates the beacon intensity is low on the displayed power converter.
ACOM ER	Indicates a loss of communication between the controller and the designated AOL (uppermost) beacon.
COM ERR	Indicates a loss of communication between the controller and the power converter or the controller and the MOD1 RLC Output PCB's
CFG ERR	Indicates too many devices have been added to the system based on the configuration of the controller or the addressing switch has been selected to the wrong position.
PC(X) J06	Serial port is not responding. The cable may be disconnected or damaged.
PC(X) SYN	Indicates that PCB 2 is not receiving the PCB1 J04 flash start signal or that the PCB 2 flash confirmation signal is late (unit is flashing out of sync or at an incorrect rate).
GPS ERR	Indicates that the controller has not received a synchronization signal from the FTW 170 for at least one hour. (Applicable only if GPS alarm is enabled.)
VERS ERR	Indicates a firmware version incompatibility between one or more interface boards.
PC(X) XCAT	Indicates that the PC hardware is not capable of performing the current catenary configuration.
POP OVR	The controller has found more connected devices than it can support.

Note: (X) indicates the number of the PC with the error condition. Example: PC2 NITE

## **Power Converter**

### **Operation Overview**

The power converter component layout is shown in Figure 4-2 and wiring diagram in Figure 2-20.

The incoming AC Line (120-240 VAC 50/60Hz) is connected to terminal strip TB2. Mounted on TB2 are a Metal Oxide Varistor (MOV1) which reduces line surges and transients and a noise suppression capacitor (C1) which ensures compliance with FCC conducted emissions limits. Ferrite L1 provides exceptional protection from lightning induced surges and EMI on the incoming power conductors. A Power Disconnect Switch mounted on the right side of the enclosure disconnects AC power when the door is opened. From the Disconnect Switch, AC Power is supplied to the AC/DC Power Supply (MOD4) and Dual Interface (PCB1).

The AC/DC Power Supply Module (MOD4) inputs universal AC input power and outputs 48VDC to the Filter PCB (PCB2A). The Filter PCB distributes 48VDC to the output driver modules and Capacitor PCB. The Micro PCB (PCB2B) mounts on top of the Filter PCB and controls operation of the driver modules via RJ style cables.

The White Driver Modules (MOD1 & MOD3) provide drive currents for and monitors health of the white LEDs. The Capacitor PCB (PCB3) provides energy

storage for the high current pulses supplied to the white LEDs.

The Red Driver Module (MOD2) provides drive currents for and monitors health of the red LED's.

The white and red driver module outputs are connected to the flashhead terminal strip (TB1) through ferrites L2 and L3 which provide protection from lightning induced surges and EMI on the flashhead cable.

The Dual Interface PCB (PCB1) provides overall control of the power converter. It receives communication from the external controller via connector J2 including mode control and synchronization commands. Sent to the controller are alarm reports and fault details. The Dual Interface PCB links to the Micro PCB (PCB2B) with control outputs (J04), alarm inputs (J05), and serial communication (J06). The Dual Interface PCB has a universal AC input power supply.



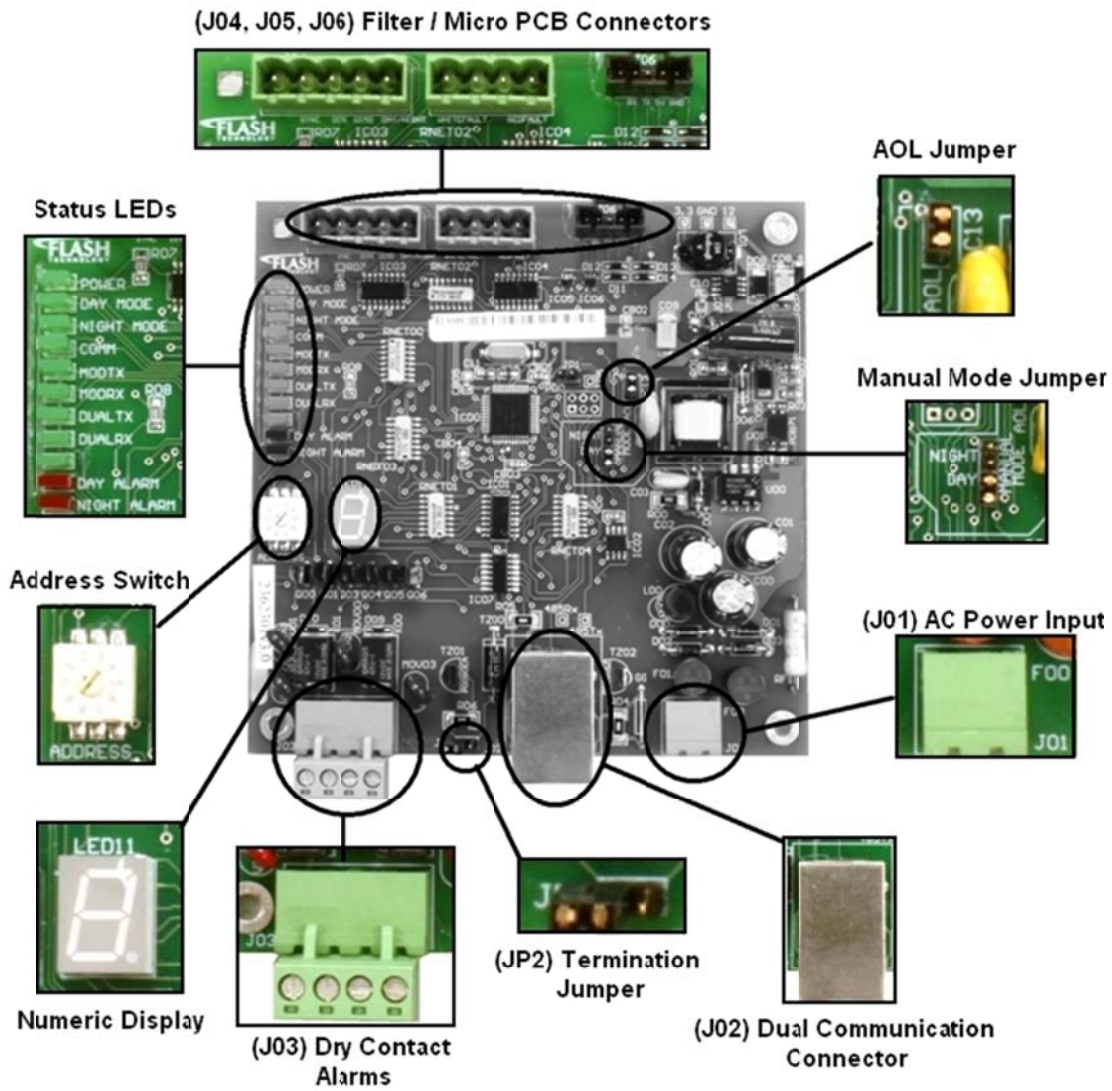

Figure 1-3 – PCB1 Dual Interface Board

Table 1-8 – Dual Interface PCB Connections

Connector	Function
J01	AC Power Input
J02	Dual Communication Connector to Controller and Multiple PC Interface
J03	Dry Contact alarm outputs
J04	Control outputs to Filter PCB (PCB2A)
J05	Alarm inputs from Filter PCB (PCB2A)
J06	Serial communication to Micro PCB (PCB2B)

Table 1-9 – Dual Interface PCB LED's

LED	Indication
POWER	Green when power is applied to the Dual Interface PCB
DAY MODE	Green continuous when power converter is in DAY mode, blinking when in manual WHITE DAY
NIGHT MODE	Green continuous when power converter is in NIGHT mode, blinking when in manual NIGHT
COMM	Green continuous when valid communication to controller is established
MODTX	Green blinking when Dual Interface is transmitting data to the controller
MODRX	Green blinking when Dual Interface is receiving data from the controller
DUAL TX	Green blinking when Dual Interface is transmitting data to the Micro PCB
DUAL RX	Green blinking when Dual Interface is receiving data from the Micro PCB
OPTION	Not Used
DAY ALARM	Red when power converter has a Day fault
NIGHT ALARM	Red when power converter has a Night fault

Table 1-10 – Dual Interface PCB Jumpers

Jumper	Function
AOL	N/A AOL mode is programmed in the Configuration menu for Catenary Lighting systems.
MANUAL MODE	Selects Manual Mode Operation
JP2	Termination Jumper is shorted across both pins on multiple beacon systems on the last power converter in communication Line.

Table 1-11 – Dual Interface PCB Address Switch

Switch	Function
ADDRESS SWITCH	Assigns a unique address for communication with the controller.

Table 1-12 – PCB1 Numeric Display

Display	Function
NUMERIC DISPLAY	Indicates the Address switch setting for the PC as a confirmation it is set correctly. The decimal point will be lit if the unit is programmed as an AOL.

## Micro/Filter (PCB2)

The Micro/Filter PCB2 is an assembly of two stacked PCB's, the Micro (PCB2B) on top and the Filter (PCB2A) on bottom. See Figure 4-2

Table 1-13 – Filter PCB Connections (PCB2A)

Connector	Function
J1	48VDC input power to the module
J2	Control Inputs from Dual Interface PCB
J3	Alarm outputs to Dual Interface PCB
J4,5,7,9,10	DC output to Driver and Capacitor modules

Table 1-14 – Micro PCB Connections (PCB2B)

Connector	Function
J1-4	Communication to Driver Modules
J7	Serial communication to Dual Interface PCB

Table 1-15 – Micro PCB LED's (PCB2B)

LED	Indication
LED1	Status of the flashhead. Blinks if a fault is detected by micro/filter module.
LED2	Pulses once every time the flashhead flashes

## Red Driver Module (MOD2)

The voltage across the pins of J3 fluctuates between 0 VDC and +105VDC each time the red layer flashes. This gives a pulse to the LED on the module causing it to flash. See Figure 4-2 for MOD2 location.

Table 1-16 – Red Driver Module Connections

Connector	Function
J1	48VDC input power to the module
J2	Communication to Microcontroller PCB
J3	Flashhead red beacon output

Table 1-17 – Red Driver Module LED's

LED	Indication
LED1	LED1 is powered from the output of this module. It will light if the output voltage exceeds about 50V. If this is lit, it is likely the driver module is working.

## White Driver Modules (MOD1 & MOD3)

Each White Driver Module supplies 1.5A, ~100ms duration, current pulses to the White LEDs. Each Module drives two strings of LEDs. See Figure 4-2 for MOD1 & MOD3 locations.

During the 100ms flash of white light, the light engine receives about 600W of power. During this period the energy is delivered from the large storage capacitors on the PCB3 capacitor board, which are constantly being charged by the Driver Module. When operating normally in day mode, the voltage on the pins of J4 (the capacitor voltage) is about 120-140V. The exact voltage is dependent on the cable length between the power converter and flashhead. Should one or more strings become disconnected or go open circuit, this may rise to about 180-190Vdc. If while connected to the LEDs this voltage is unable to rise to about 120V, this may indicate a problem with the Driver Module.

Circuits on this board monitor the current pulses in each LED string and send a Fault Monitor signal to the micro controller via J2, along with timing and other control signals.

Note: It may take several seconds after power up before the LEDs will flash, due to the time taken to charge the large storage capacitors.

Table 1-18 – White Driver Module Connections

Connector	Function
J1	48VDC input power to the module
J3	Output to flashhead white LEDs. There are three conductors on this connector, one for the common positive connection and two returns.
J4	Connection to white strobe energy storage capacitor on Capacitor PCB.

Table 1-19 – White Driver Module LED's

LED	Indication
LED1 - 3	LEDs 2 and 3 are powered from the same current sources that drive the flashhead white LEDs. Therefore, if both of the LEDs are flashing it is likely that the White Driver module is OK. Any that are not flashing (continuous on or off) might indicate a problem with that output.
LED4	LED 4 indicates the voltage on the common anode output.

## Capacitor PCB (PCB3)

**Safety Warning:** This board holds a number of large capacitors for storage of the energy required during the beacon's flash duration. These capacitors may be charged with voltages up to about 185 VDC. Associated with each capacitor is a red indicator LED. When lit, this indicates the capacitor voltage is 50 VDC or higher. LED's may be off if not in day mode. When power is removed from the module the capacitors automatically discharge. The LED's will remain lit until the voltage drops below 50 VDC. Verify voltage readings on TB1 of the beacon cable connection before servicing the system. Therefore, do not attempt any maintenance until capacitors have been allowed time to discharge to a safe level and all red indicator LED's have gone out. See Figure 4-2.

Table 1-20 – Capacitor PCB Connections

Connector	Function
J1	Capacitor for White Driver MOD1
J4	Capacitor for White Driver MOD3
J5	48VDC Power Input

Table 1-21 – Capacitor PCB LED's

LED	Indication
LED1	High Voltage Visual Indicator
LED2	High Voltage Visual Indicator
LED3	High Voltage Visual Indicator
LED4	High Voltage Visual Indicator

## AC/DC Power Supply Module (MOD4)

The AC/DC Power Supply Module receives 120-240 VAC 50/60Hz on the Input connector and supplies 48 VDC from the output connector to the PCB2A Filter Board. The LED on the module will illuminate verifying the presence of the 48 VDC output voltage. See Figure 4-2 for MOD4 location.

Table 1-22 – AC/DC Power Supply Module Connections

Connector	Function
INPUT	AC Power Input
OUTPUT	48VDC Output

## Section 2 – Mounting and Installation

### Unpacking

Inspect shipping cartons for signs of damage before opening them. Check package contents against the packing list and inspect each item for visible damage. Report damage claims promptly to the freight handler.

### Tools

Flash Technology suggests the following tools for installation and maintenance:

- 1/8" non-flared flat blade screw driver (included)
- 9 or 12 inch, flat blade #2 screwdriver
- #2 Phillips® head screwdriver
- Set of combination wrenches
- Long-nose pliers
- Assorted nut driver handles: 1/4", 5/16", 3/8" recommended
- Digital volt-ohm meter
- Wire strippers

### Controller Installation

See System Wiring Diagram Figure 2-12 or 2-13 and Drawing Notes for additional installation requirements.

### Access WARNING

Read the warning on Page ii now. Disconnect primary power before opening enclosures.

### Verifying the Installation

Upon completion of the system installation, verify the main menu display shows the correct configuration. Enter the Diagnostic Menu of the controller and confirm that no Alarms or Errors exist. Enter the Lighting Inspection Menu at the end of every install and verify the system is responding correctly.

### Controller

Latches secure the cover. When you release these, you can swing open the cover for internal access.

### Mounting

Flash Technology does not furnish mounting hardware unless ordered as part of an installation kit. Use the following guidelines for mounting the controller. Ensure that adequate space exists around the equipment for access during installation, maintenance and servicing. Allow space for airflow around the controller. See Figure 2-7 for controller enclosure and mounting dimensions.

### Wiring

This manual may not contain all the information about installation wiring required for your installation.

**Note:** If installation drawings prepared specifically for your site disagree with information provided in this manual, the installation drawings should take precedence. *Consult any site-specific installation wiring diagram supplied with your equipment.*

**Note:** Flash Technology wiring diagrams define only minimum requirements recommended for satisfactory equipment operation. *It is the responsibility of the installer to comply with all applicable electrical codes.* You can find conduit and other distribution wiring details on electrical installation diagrams provided by Flash Technology or others. All installation wiring should have an insulation rating of 600 volts. Wiring should be sized to satisfy the load demand of the controller and the power converters. *Read the notes on the installation wiring diagrams supplied both in this manual and with the equipment.*



## AC Line

The AC Line connections are made to TB1 in the lower right of the cabinet. The controller operates from universal input power (120-240 VAC 50/60Hz) with no configuration. Connect L1, L2, and Ground. AC input power conductor size depends on the service voltage, the distance from the source and the number of power converters. Use 150 VA per power converter for load calculations. Also see Note 5 from the system wiring diagram.

**Important! For proper operation and optimal protection from Lighting and EMI, ensure that Earth Ground is wired to the Ground (Green) Terminal.**

## Communication Cable

The communication cable provides communication between the controller and power converter. It is connected at PCB1 J7.

A Communication Cable Kit is provided with each power converter consisting of a cable and two strain relief connectors with inserts for the cable. One strain relief is to be installed in the power converter and the other in the controller (or next power converter). If flexible conduit is not being utilized for the installation, follow the method below for routing the cable.

## Wiring Procedure

1. Install the 3/4 inch strain relief connector on the Enclosure.
2. Slide the dome nut over the cable.
3. Install the connector insert over the cable with tapered end facing away from the connector.
4. Push the connector through the housing from outside the enclosure.
5. Push the cable insert into the strain relief housing.
6. Plug the cable into PCB1 J7 and position the cable, providing a small amount of slack inside the cabinet to reduce stress on connector J7. Coil excess cable equally between enclosures See Figure 2-1. Do not cut and splice to remove excess cable.
7. Tighten the strain relief connector dome nut.



Figure 2-1 – Communication Cable

### **Photocell Wiring**

The photocell input to the controller is on PCB1 J4. The photocell is supplied with pigtails for connection to wires that connect to the controller. It may be located any practical distance from the controller. The recommended minimum wire gauge is #16 AWG if splicing is necessary to extend the provided length.

### **Photocell Mounting**

Mounting and outline dimensions for the photocell are shown in Figure 2-11. The photocell uses a male 1/2" NPT for mounting. Use the following guidelines to mount the photocell:

- Locate the photocell where it has an unobstructed view of the polar sky.
- It must not view direct or reflected artificial light.
- The photocell should be supported directly by electrical conduit and not mounted underneath the controller where it could be shadowed.
- Ensure that the installation is watertight.

### **Dry Contact Alarm Outputs**

Dry contact alarm outputs for the controller are available if the system is not

monitored by Flash Technology FTW 174 RS-485 communication.

The alarm outputs (Photocell Alarm, Power Fail) are available on PCB1 J1. A single Common connection for the two alarm contacts is provided. Figure 2-16 provides the recommended dry contact interface connections into the FTW 174 interface connector. Figures 2-17 and 2-18 provide examples of dry contact wiring for monitoring equipment supplied by others.

***NOTE: Other manufacture's dry contact common termination points should be verified on their monitoring equipment.***

### **FTW 170 Wireless GPS Sync Input**

The wireless sync input connection is on PCB1 J4. Refer to Figure 2-21 and the FTW 170 Wireless GPS manual for installation instructions.

### **FTW 174 Wireless Unit Communication**

The connections for the RS 485 FTW 174 Wireless Unit are on PCB1 J2. Previous versions of the FTW Monitoring units will not interface through RS 485. Refer to the FTW 174 Wireless manual for installation instructions.

## **Power Converter Installation**

### **Access**

#### **Warning!**

Read the warning on Page ii now.  
Disconnect primary power before opening enclosures.

### **Mounting**

Latches secure the cover. When you release these, you can swing open the cover for internal access.

Flash Technology does not furnish mounting hardware unless ordered as part of an installation kit. Use the following guidelines for mounting the power converter.

Ensure that adequate space exists around the equipment for access during installation, maintenance and servicing.

Allow space for airflow around the controller.

You must use a bonding strap on a stainless steel or galvanized bolt through the power converter case leg. Connect the strap to the site grounding system. See Figure 2-8 for power converter enclosure dimensions and mounting feet.

### **Mounting Adapter Panel (Optional)**

The optional Mounting Adapter Panel allows for easier installation of the FTS 364X system by removing the need for modifying the existing outdoor H-Frame to compensate for the size differences between the controller and power converter (see Figure 2-9). This should be installed when upgrading from previously installed Flash Technology products and new installations. The H-Frame may require adjustment on non-Flash Technology lighting products if the adapter panels are requested. Please contact the Flash Technology parts

department at 1-800-821-5825 if this option is desired.

### **Wiring**

#### **AC Line**

The AC Line connections are made to TB2 in the lower right of the cabinet. The power converter operates from universal input power (120-240 VAC 50/60Hz) with no configuration. Connect L1, L2, and Ground. See System Wiring Diagram Figure 2-13 and Drawing Notes for additional installation requirements.

**Important! For proper operation and optimal protection from Lightning and EMI, ensure that Earth Ground is wired to the Ground (Green) Terminal.**

#### **Flashhead Cable**

The flashhead cable connects to TB1 in the lower left of the cabinet. The Flash Technology flashhead cable (PN 4362100) provides optimal system performance while minimizing vulnerability to Lighting and EMI (Electromagnetic Interference). The cable provides ten AWG18 conductors with overall mylar shield. Eight conductors are required: two for the Red LEDs, and six for the White LEDs.

Note: All ten conductors should be connected at the appropriate terminal.

To provide optimal Lighting and EMI protection, a metal shielded strain relief connector is provided preinstalled on the enclosure. A matching connector is preinstalled on the flashhead. This connector provides 360 degree connection of the flashhead cable shield to the metal enclosure which is superior to connecting the Drain wire alone. It is recommended to provide a five foot service loop at the power converter and flashhead level.

## Wiring Procedure

1. Prepare the flashhead cable
  - a. Strip off 12 inches of outer jacket being careful to not cut the mylar shield.
  - b. Cut the shield leaving 1 inch of shield remaining.
2. Install the flashhead cable
  - a. Slide the metal connector dome nut over the cable.
  - b. Insert the cable into the metal strain relief connector.
  - c. Position the cable so that the mylar shield protrudes approximately 1/4 inch into the power converter.
  - d. Important: Tighten the dome nut securely.  
**This is important for optimal Lightning and EMI protection by insuring that the cable shield is properly grounded to the flashhead body.**
3. Connect the ten conductor flashhead cable to the terminal strip TB1 using the provided non flared flat tip screwdriver.  
**Important! Be careful to match colors correctly to ensure proper operation and avoid damage to electronics.**
4. Connect the flashhead Drain wire to the Ground (Green) Terminal.



Figure 2-2 – FH Cable Install (PC)

## Securing the Cable

Flash Technology provides the material for securing the flashhead cable to a skeletal structure with the following technique. Always adhere to local electrical codes that could supersede this recommended technique:

1. Run the cable along one of the tower legs and wrap two full turns of two-inch Scotchwrap™ #50 tape, or the equivalent, around the cable and tower leg at regular intervals every 4 to 5 feet (1.5 meters) per NEC.



2. Wrap three full turns of one-inch Scotchwrap Filament #890 tape, or the equivalent, over the Scotchwrap #50 tape.



3. Wrap four full turns of two-inch Scotchwrap #50 tape, or the equivalent, over the Scotchwrap Filament #890 tape.



4. Perform steps 1 through 4 also directly above and below any tower leg flanges that the cable may cross. The cable should be spaced approximately 1 inch from the edge of each flange.

## Communication Cable

The communication cable provides communication between the controller and power converter. Its connection is on PCB1 J2. Two positions are available at J2 for connecting multiple power converters.

A communication cable kit is provided with each power converter consisting of a cable and two strain relief connectors with inserts for the cable. The strain relief connectors will not be used if flexible conduit is utilized to route the cable between the controller and power converter. Follow the method below for routing the cable if flexible conduit is not being utilized.

### Wiring Procedure

1. Install the 3/4 inch strain relief connector on the Enclosure.
2. Slide the dome nut over the cable.
3. Install the connector insert over the cable with tapered end facing away from the connector.
4. Push the connector through the housing from outside the enclosure.
5. Push the cable insert into the strain relief housing.
6. Plug the cable into PCB1 J2 and position the cable, providing a small amount of slack inside the cabinet to reduce stress on connector J2. Coil excess cable equally between enclosures See Figure 2-3. Do not cut and splice to remove excess cable.
7. Tighten the strain relief connector dome nut.

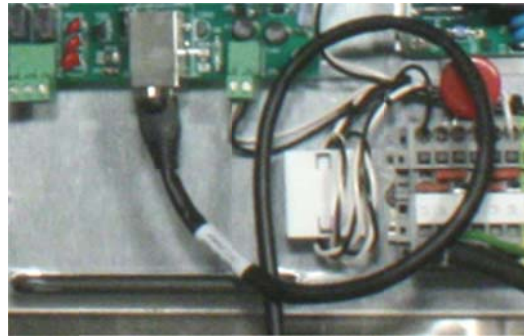

Figure 2-3 – Communication Cable Install

### Dry Contact Alarm Outputs

Dry contact alarm outputs for the power converter are available for use if the system is not monitored with a Flash Technology wireless unit (FTW 174). The alarm outputs (Day Alarm, Night Alarm) for each power converter are available on PCB1 J03. The alarm contacts are standard as Normally Closed. Figure 2-16 provides the recommended dry contact interface connections into the FTW 174 interface connector. Figures 2-17 and 2-18 provide examples of dry contact wiring for monitoring equipment supplied by others.

***NOTE: Other manufacture's dry contact common termination points should be verified on their monitoring equipment.***

***NOTE: Please refer to Figures 2-12, 2-13, 2-14 and 2-15 for recommended conductor routing between power converters, controller and monitoring system when multiple power converters are necessary to mark an obstruction.***

## Configuration

### Power Converter Address

Each power converter must be assigned a unique address for communication with the controller. Select a unique address (1 – 9) for the power converter using the rotary switch on the Dual Interface PCB (PCB1). See Figure 1-3 and Table 1-11)

### AOL Designation

The AOL junper is disabled on Catenary lighting systems. AOL designation is set in the Configuration menu for Catenary lighting systems.

### Power Converter Termination Jumper

The JP 2 termination jumper is shorted across both pins on multiple beacon systems on the last power converter in

communication line. (See Figure 1-3 and Table 1-10)

### Power Converter Night operation

On the Micro/Filter PCB (PCB2), switch SW1 selects whether the system operates in Red or White at Night. Confirm that the switch is set correctly.



Figure 2-4 – PCB2 Micro/Filter SW1 Configuration

## **Flashhead Installation**

### **Mounting**

**Flash Technology recommends the installation of one or more lightning rods near the uppermost installed flashhead. The copper lightning rods should extend a minimum of three feet above the height of the flashhead within the cone of protection (approx. 18”).**

The flashhead is mounted to the tower pedestal utilizing 1/2 inch galvanized or stainless steel hardware. Six mounting holes are provided on the flashhead base (Figure 2-10). These mounting holes will align with most tower pedestals. The flashhead must be installed level to maintain light output in accordance with FAA requirements.

Ensure the flashhead is electrically bonded to the tower.

### **Wiring**

Procedure (See Figure 2-5, 2-6 or 2-13)

1. With the flashhead securely mounted to the tower, unclamp the two clamps on the either side of the cable strain relief.
2. Lift the flashhead top assembly to expose the flashhead cable terminal block.
3. Prepare the flashhead cable
  - a. Strip off 12 inches of outer jacket being careful to not cut the mylar shield.
  - b. Cut off the mylar shield except leaving 1 inch of mylar shield remaining.

4. Install the flashhead cable
  - a. Slide the metal connector dome nut over the cable.
  - b. Insert the cable into the metal strain relief connector.
  - c. Position the cable so that the mylar shield protrudes approximately 1/4 inch into the flashhead.
  - d. Important: Tighten the dome nut securely.  
**This is important for optimal Lightning and EMI protection by insuring that the cable shield is properly grounded to the flashhead body.**
5. Connect the ten flashhead cable conductors to the terminal strip using the provided small flathead screwdriver.  
**Important! Be careful to match colors correctly to ensure proper operation and avoid damage to electronics.**
6. Connect the flashhead Drain wire.
7. Ensure all wiring is tucked inside the flashhead cavity to avoid pinching.
8. Close the flashhead top assembly and secure the two clamps.





Figure 2-5 – FH Cable Connector

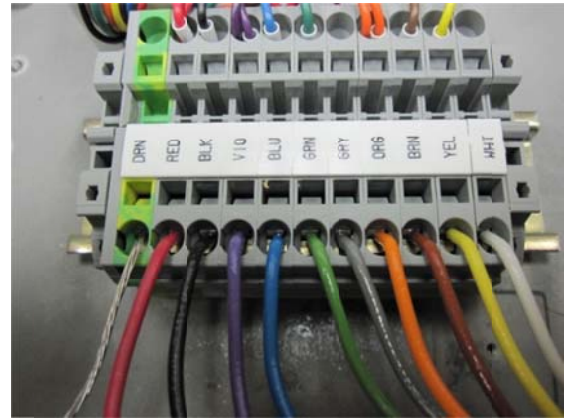

Figure 2-6 – FH Cable Terminal Block

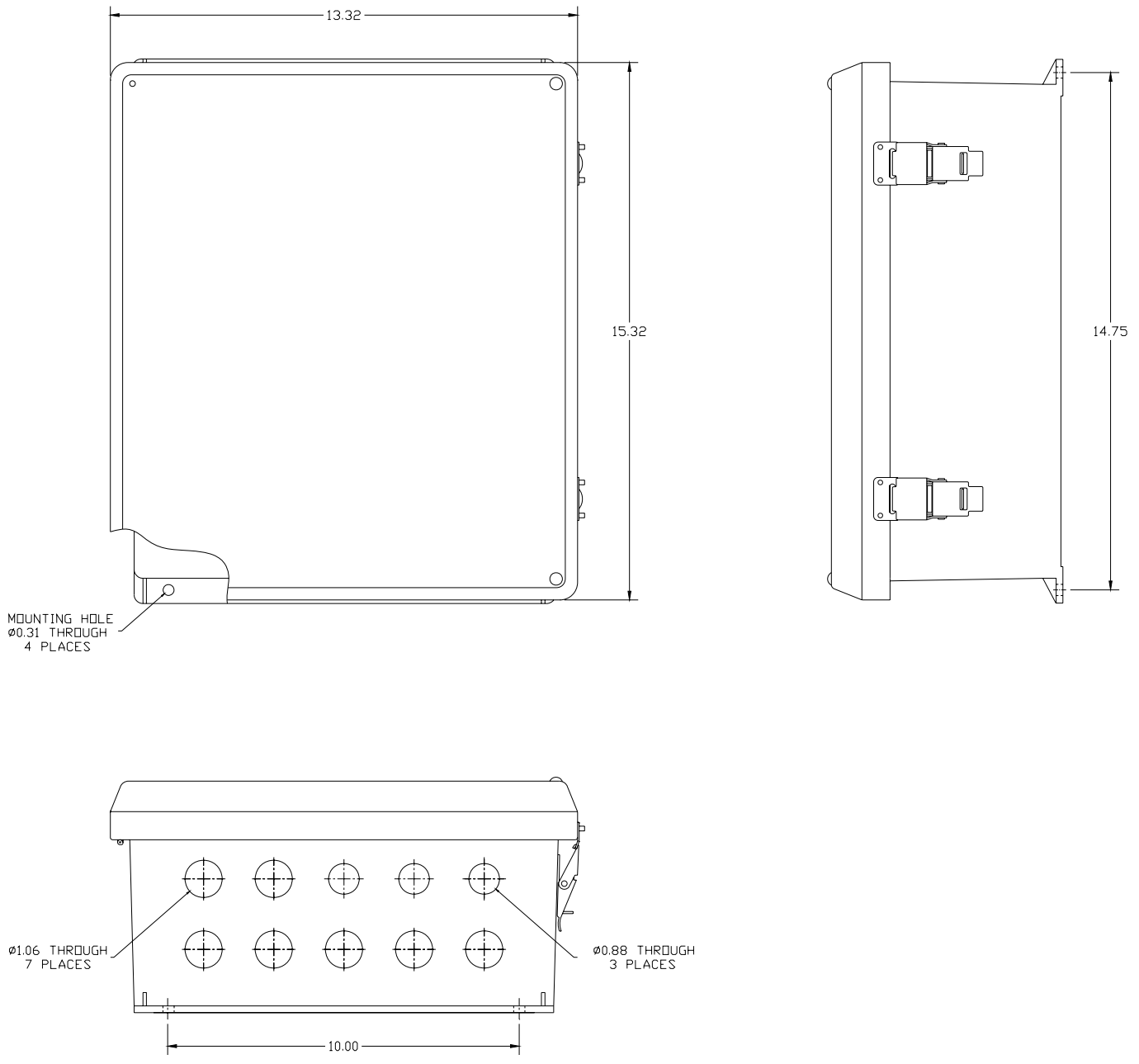

Figure 2-7 – Controller Mounting and Outline

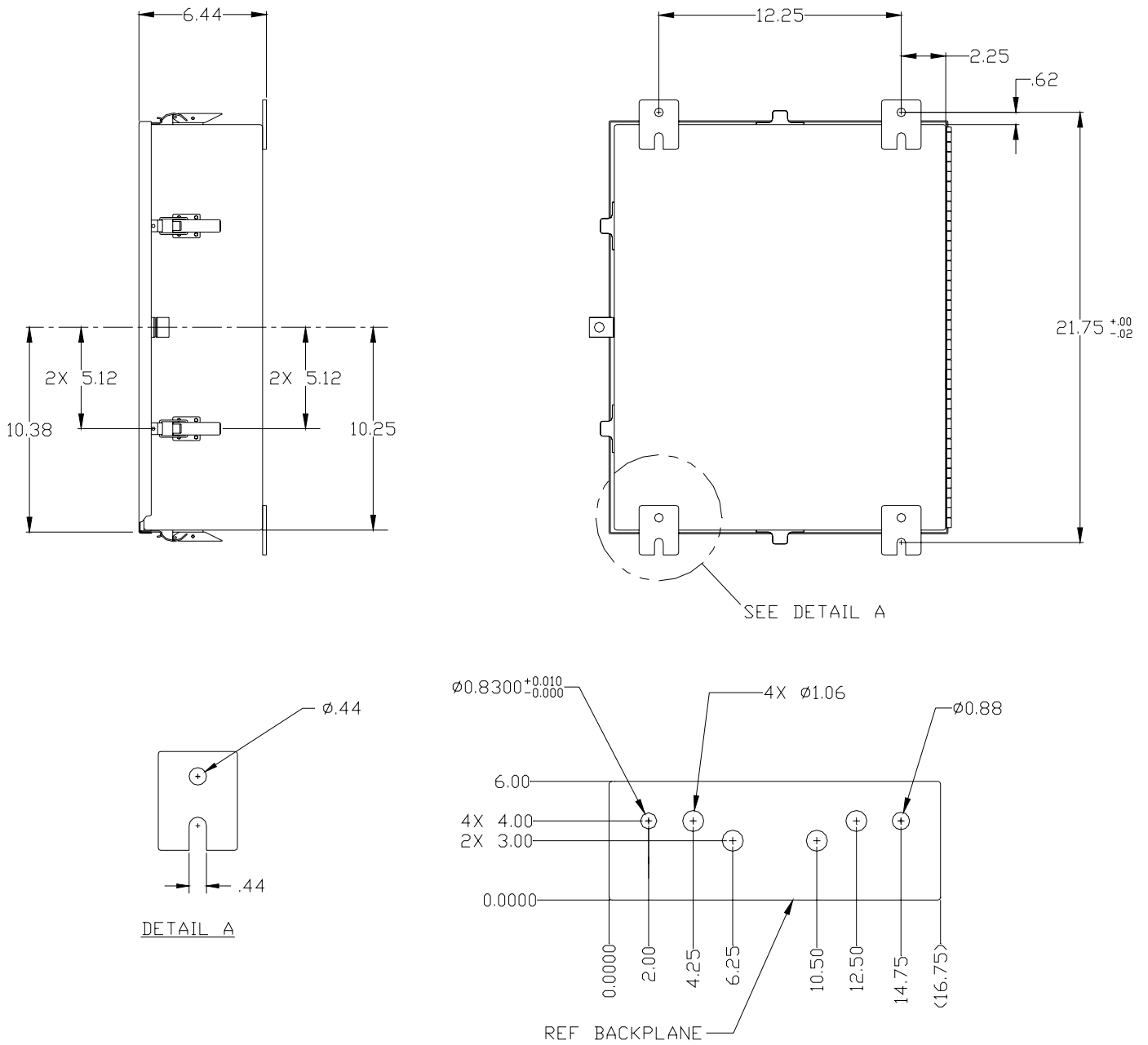
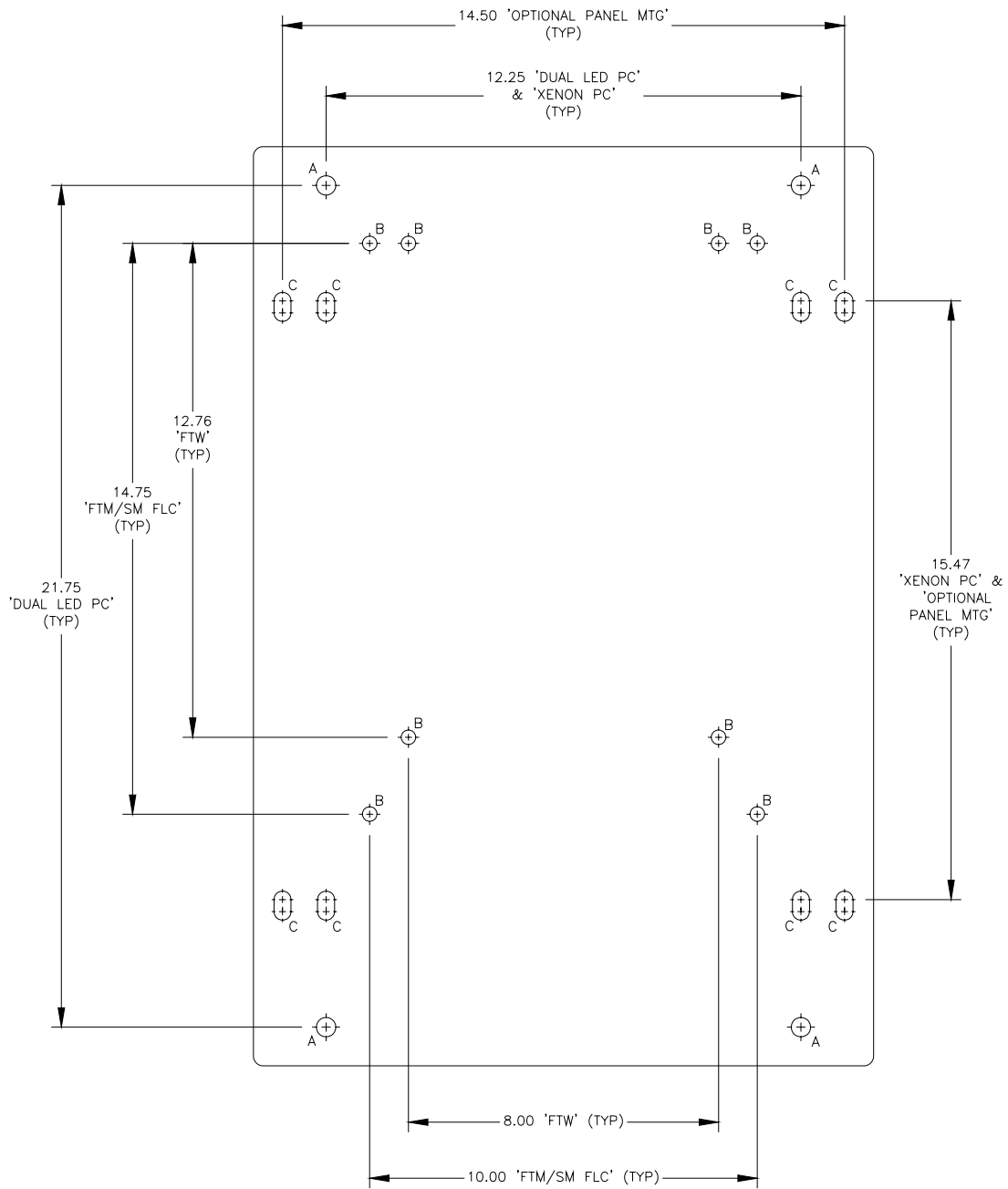
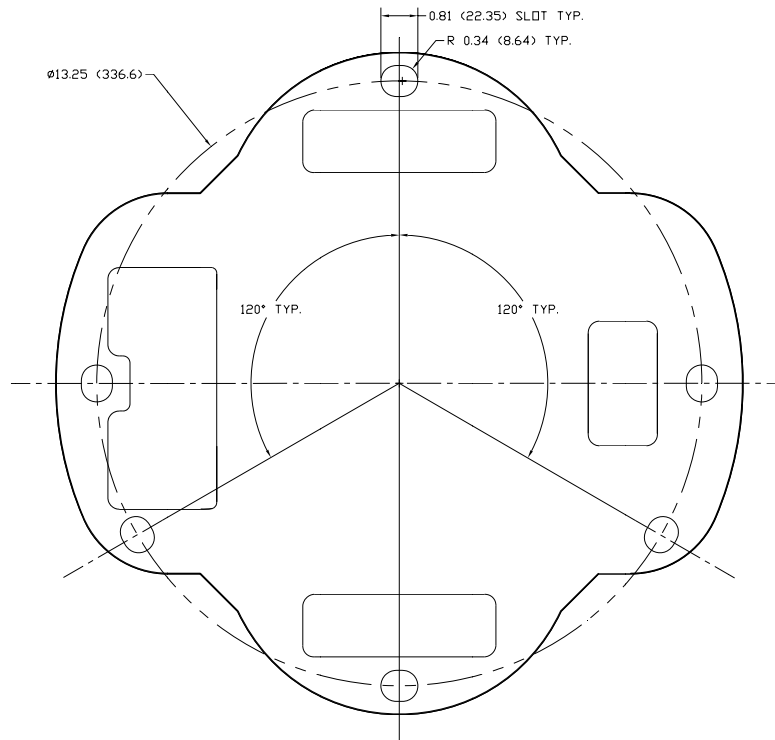
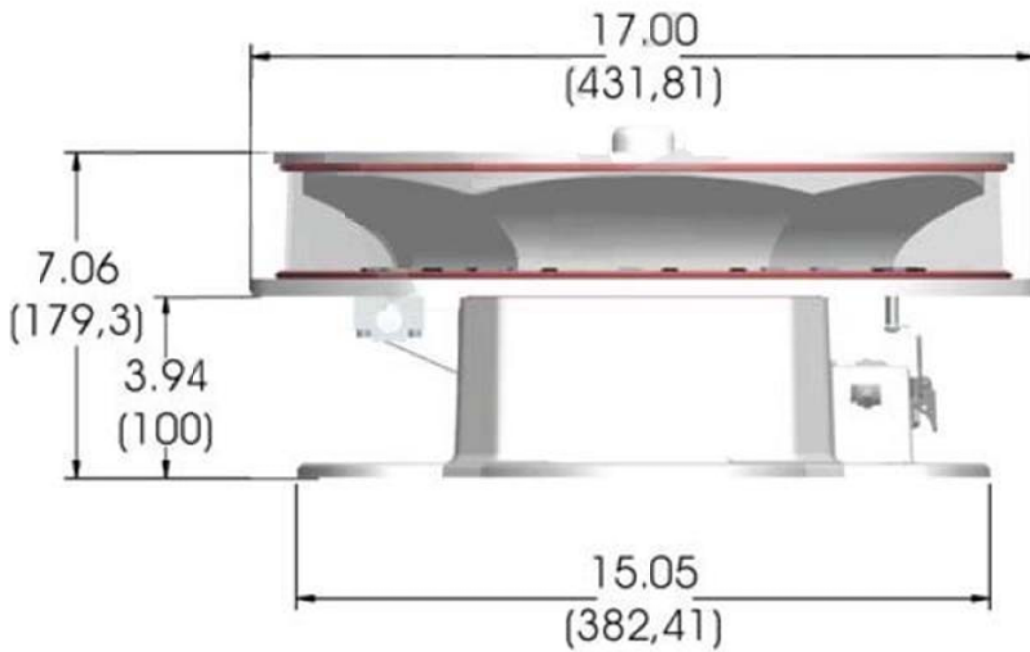

Figure 2-8 – Power Converter Mounting and Outline



HOLE CHART		
LETTER	HOLE SIZE	QTY
A	0.50" DIA THRU	4
B	0.38" DIA THRU	8
C	∅0.44" X 0.75" LG SLOT THRU	8

Figure 2-9 – Adapter Mounting Panel Mounting and Outline (Optional)



NOTE: ALL DIMENSIONS ARE IN INCHES (MILLIMETERS)

FH 3640 L-866/L-885 LED FLASHHEAD

Figure 2-10 – Flashhead Mounting and Outline

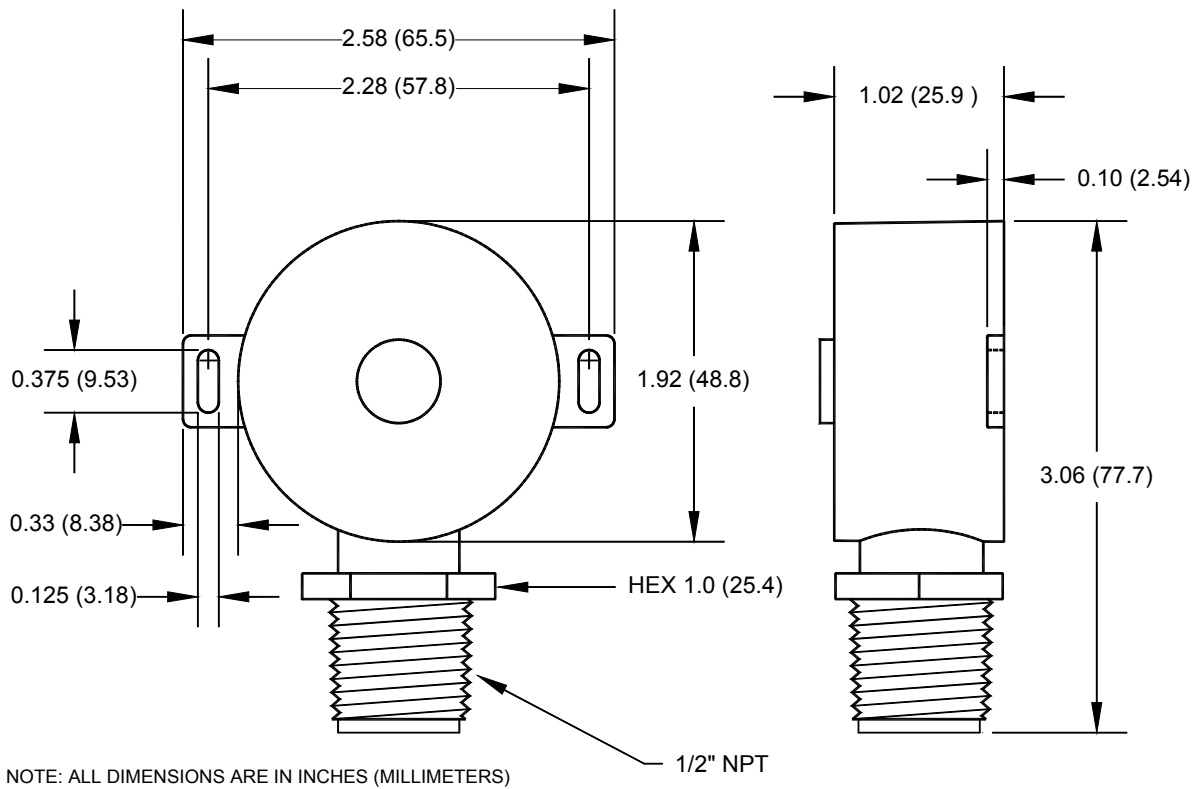

Figure 2-11 – Photocell Mounting and Outline

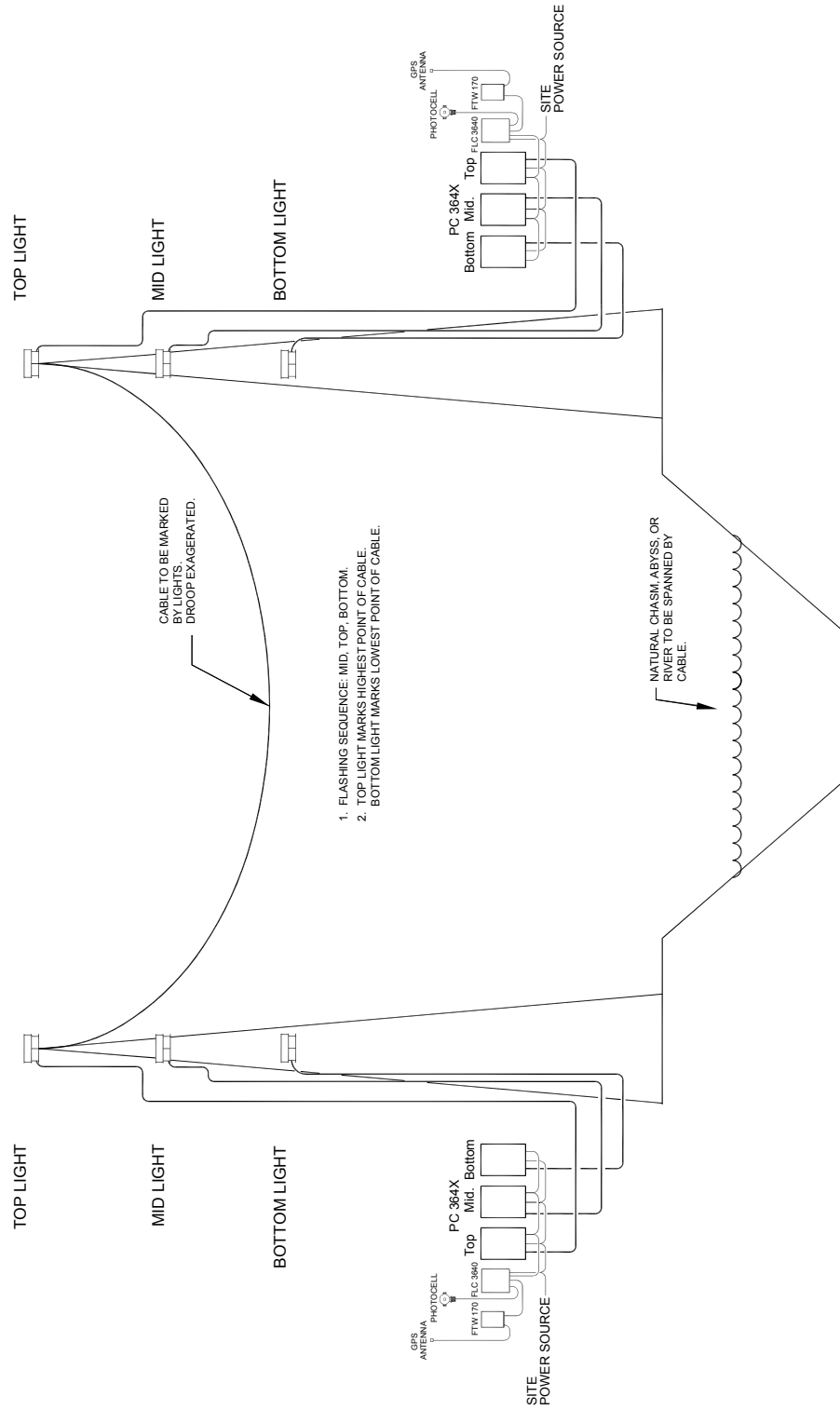

Figure 2-12 – Typical Catenary System Installation





### System Wiring Diagram Notes

1. AC input power conductor size depends on the service voltage, the distance from the source and the number of power converters. Use 150 VA per power converter to determine conductor size.
2. Flashhead cable PN 4362100, ten conductors 18 AWG minimum plus drain, overall shield. Use a continuous cable from the power converter to the flashhead without junctions or splices.
3. Dry contact alarm outputs contact rating 1 ampere, 120 VAC. Contacts shown in normal operating state (no alarms or errors).
4. User's alarm circuit not shown.
5. It is recommended that the incoming AC Line Voltage (120-240 VAC 50/60Hz) is connected to the TB1 terminal strip of the FLC 3640 controller. It is recommended to daisy chain the AC Line voltage from the controller's TB1 to the power converter's TB2 and to continue the AC line voltage distribution in this manner between additional power converters.
6. Mount the enclosures vertically.
7. Ensure the power converter enclosure is electrically bonded to the site grounding system.
8. Mount the photocell vertically at the top end of a vertical length of conduit to prevent water from entering the photocell. Face it toward the polar sky (north). Photocell cable should be two conductors 16 AWG minimum.
9. Use lightning protection for the top flashhead.

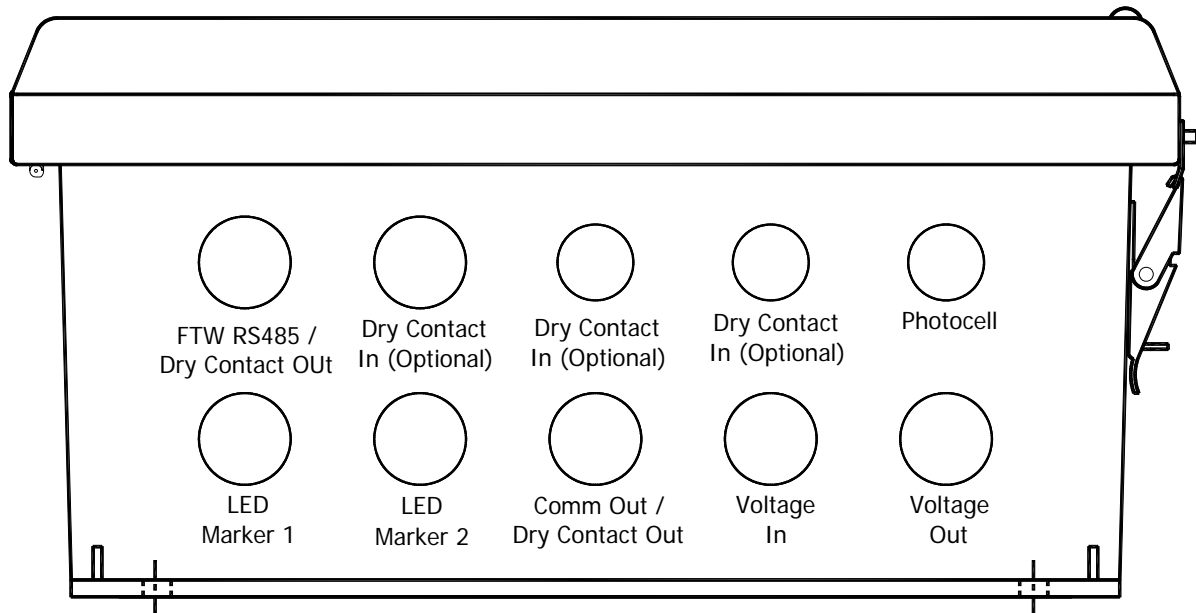

Figure 2-14 – Suggested Controller Conductor Routing to Multiple PC's

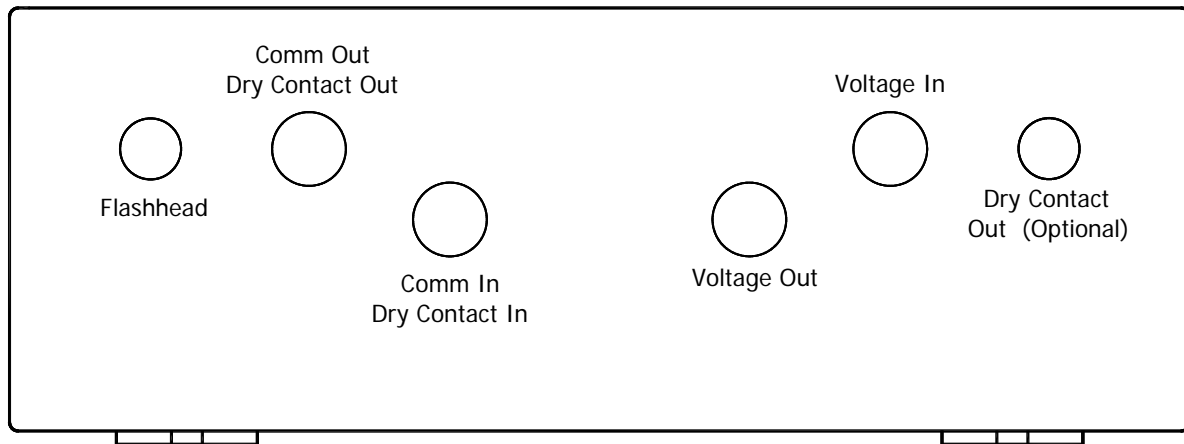

Figure 2-15 – Suggested Power Converter Conductor Routing to Multiple PC's

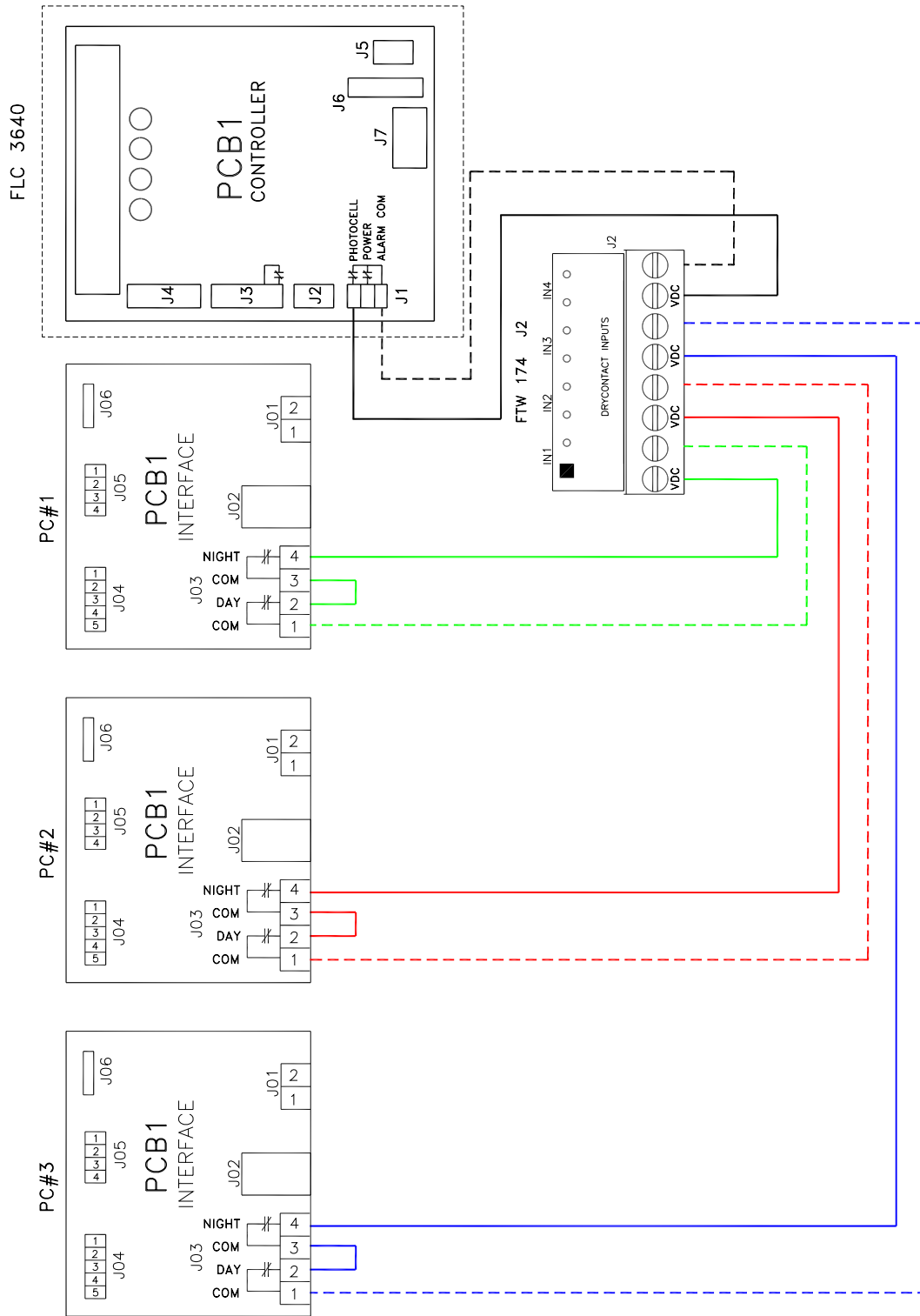

Figure 2-16 – Dry Contact Alarms For FTW 174

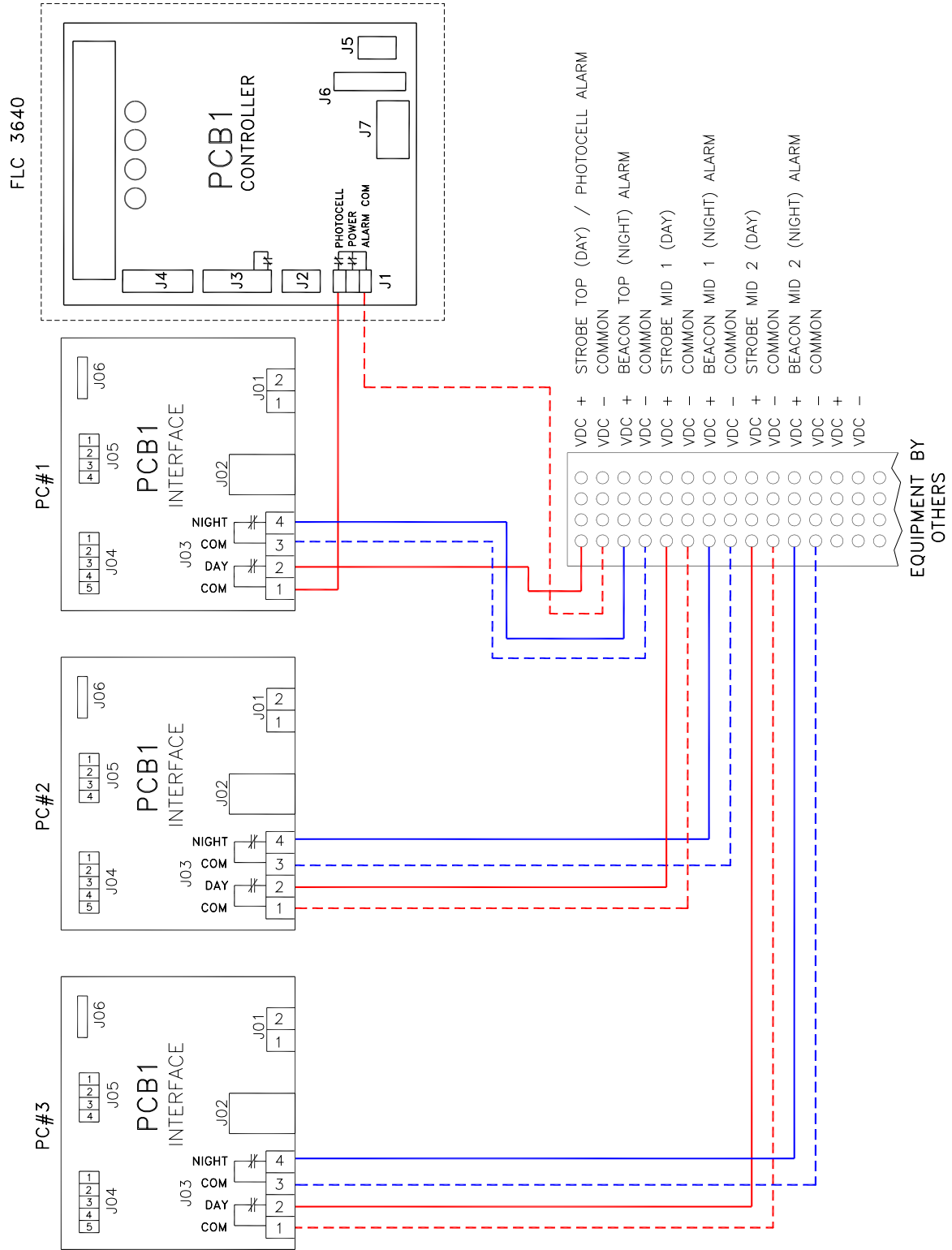

Figure 2-17 – Individual Dry Contact Alarms For Equipment By Others

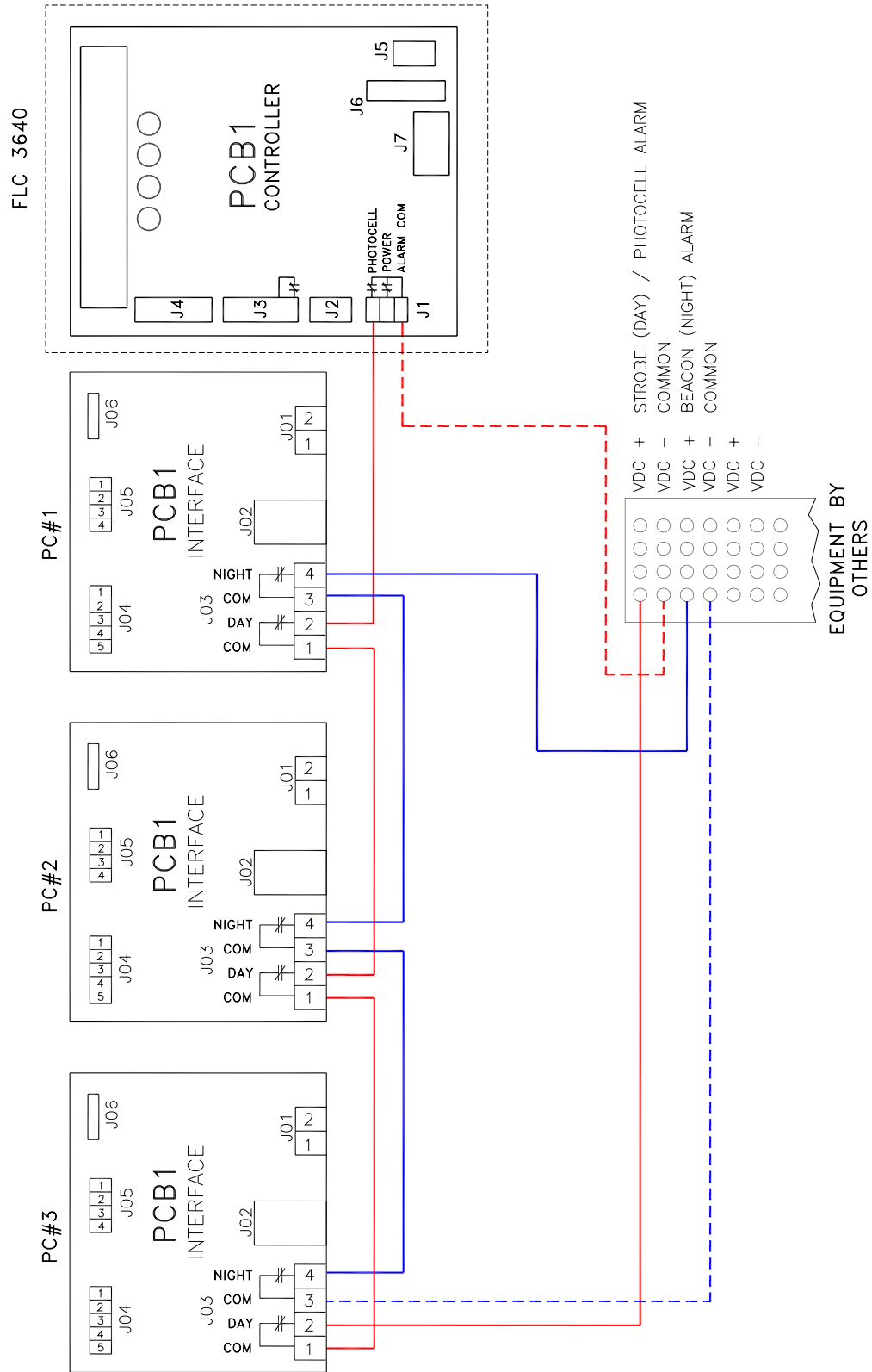
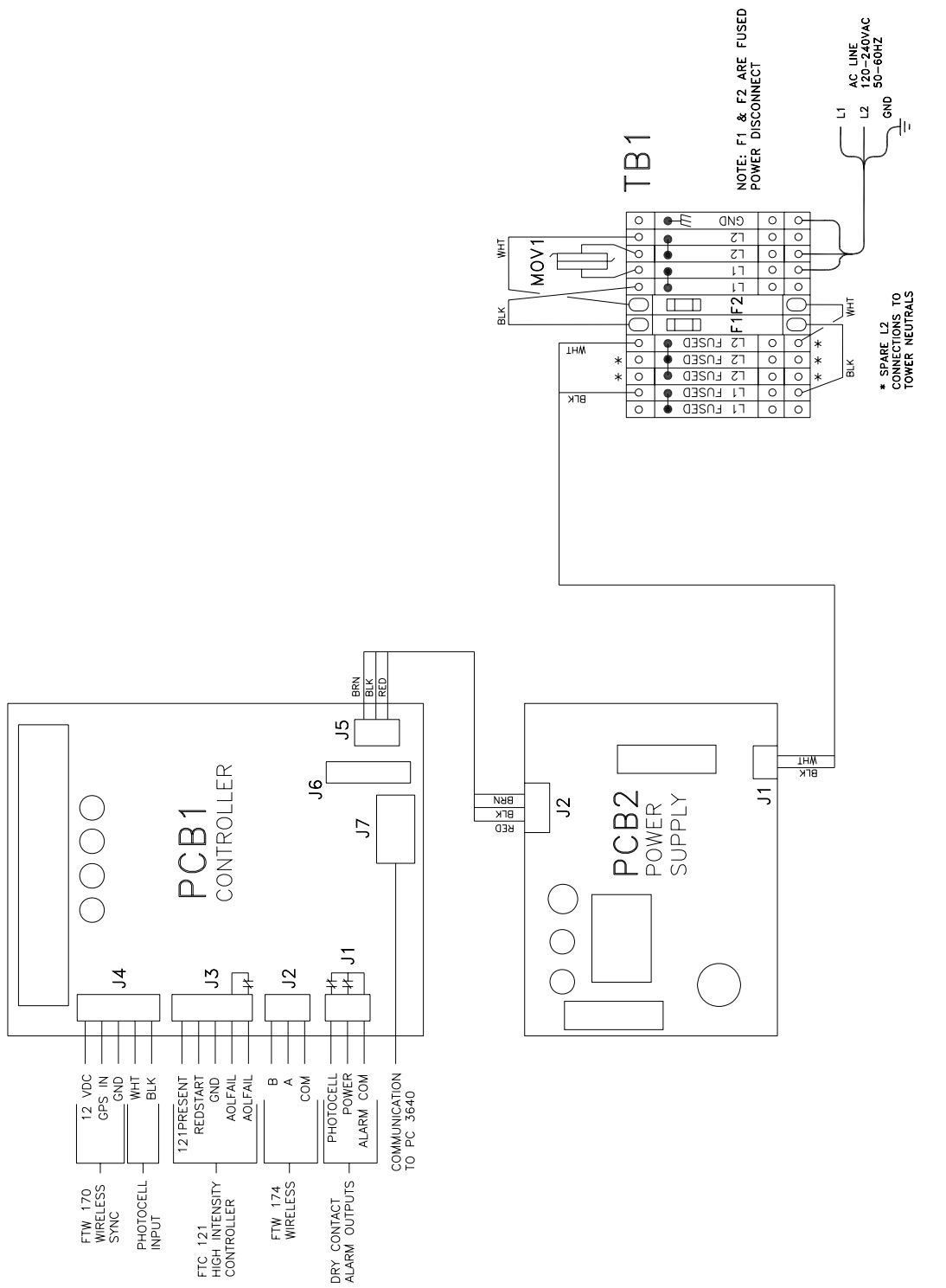

Figure 2-18 – Limited Dry Contact Alarms For Equipment By Others



FLC 3640 (120-240VAC, 50-60HZ)  
 CATENARY - INTERNAL WIRING

Figure 2-19 – Controller Internal Wiring

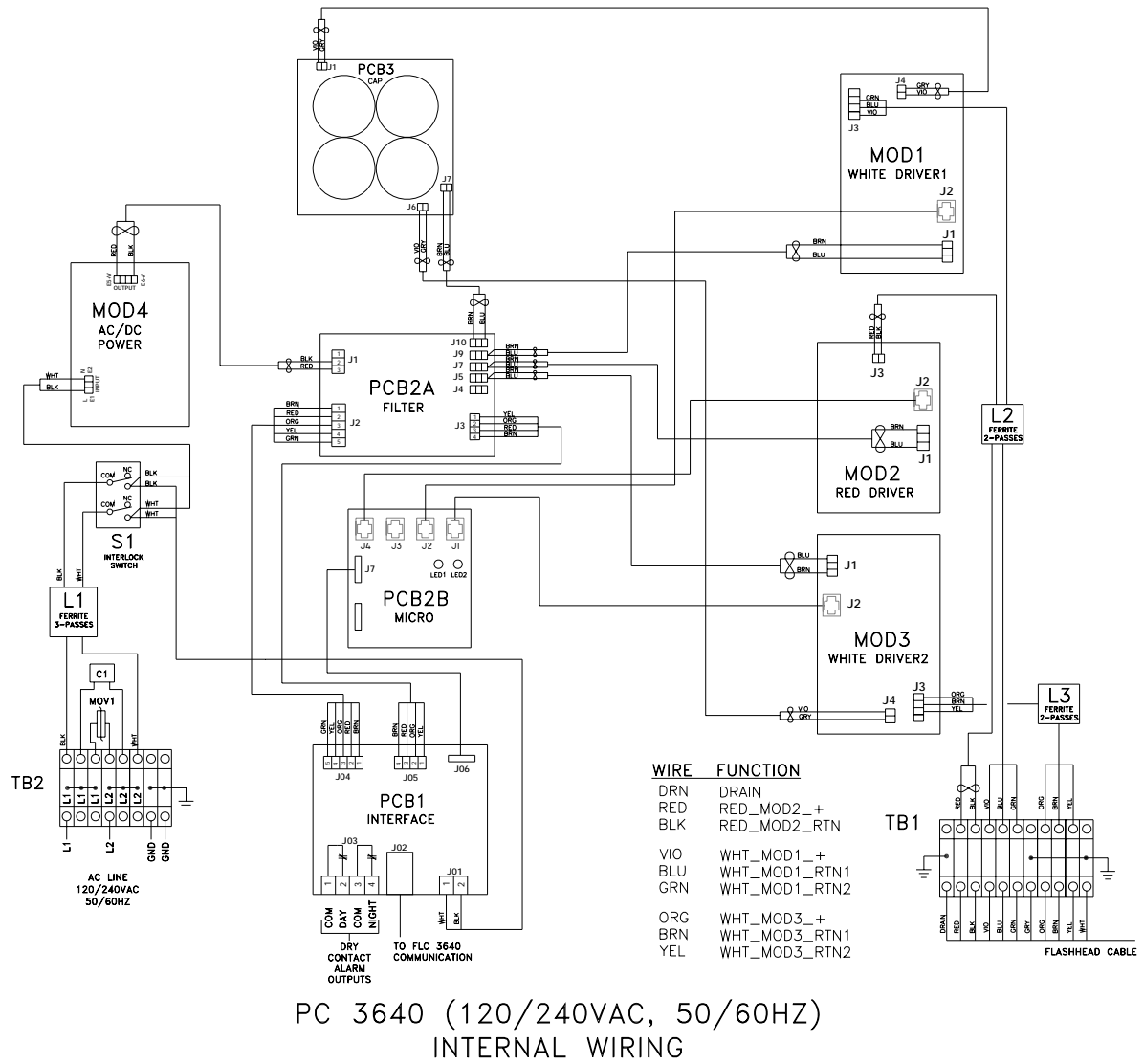

Figure 2-20 – Power Converter Internal Wiring

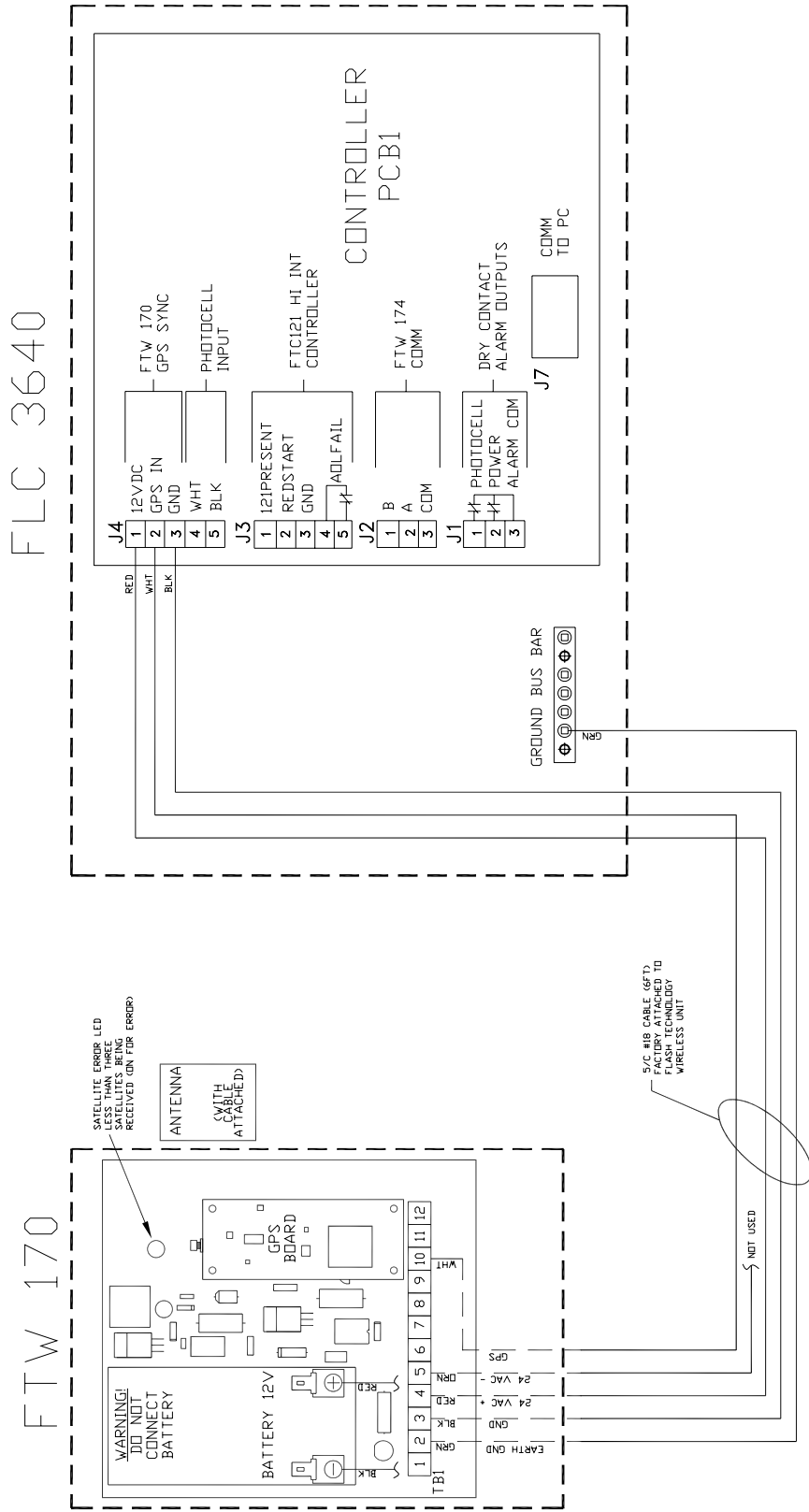

Figure 2-21 – FTW 170 Wireless GPS System Wiring Diagram



## Section 3 – Maintenance and Troubleshooting

### **Safety**

#### **WARNING**

STOP: Before proceeding read the warning on Page ii.

Work safely, as follows:

1. Remove rings and watches before opening the equipment.
2. Shut off the equipment.
3. Remove the component or connect the test instruments.
4. Replace the component.
5. Turn on the power and test the system.
6. Turn off the power and disconnect the test equipment.

### **Preventive Maintenance**

Carry out the following inspection and cleaning procedures at least once a year:

1. Verify that moisture has not accidentally entered the equipment through gaskets or seals, or collected inside as condensation.
2. Verify that all drain holes are clear.
3. Check terminal blocks and relays for corrosion or arcing. Clean or replace any component that shows evidence of high-voltage damage.
4. Check all electrical connections for tightness and verify the absence of corrosion or electrical arcing.
5. Clean the outside surface of the lens with liquid detergent and water. Wipe it gently with a soft cloth or paper towel.

### **Storage**

Store equipment indoors when not in use. Circuit boards (PCB's), when not installed in the equipment, should be kept in antistatic bags or containers.

### **RFI Problems**

The presence of radio frequency interference (RFI) can burn out components, cause a light to flash intermittently, at the wrong rate, or at the wrong intensity. RFI can enter the light by any wire to or from the unit. The circuits reject or bypass RFI, but Flash Technology cannot guarantee complete immunity. After installation, you may find it necessary to add external filters or use other methods to reduce RFI entering the equipment. To minimize interference, ensure proper installation in accordance with AC 70-7460, Appendix 1, Figure 2.

### **Component Testing**

The following procedures in Table 3-1 describe how to check most of the unit's major electrical components. Always make resistance measurements with the primary power turned off. However, you must make voltage measurements with power applied. Thus, for your safety, carry out all preliminary steps such as connecting test leads or circuit jumpers or disconnecting existing circuit connections with the power off.

Table 3-1 – Troubleshooting

Symptom	Possible Causes	Corrective Action
White LEDs will not operate, or initially operate then shut down.	<ol style="list-style-type: none"> <li>1. Cable Connection Problem</li> <li>2. LED string failure</li> <li>3. Drive module failure</li> </ol>	Check Diagnostic LED's on Strobe Driver modules. If not operating properly check power to Driver module (J1), or replace module. Check cable plugged into J2. If LED's are operating properly, check cable connections to flashhead.
Red LEDs will not operate. Diagnostic LED is lit.	<ol style="list-style-type: none"> <li>1. Control cable problem</li> <li>2. Flashhead cable Problem</li> <li>3. LED problem in flashhead</li> </ol>	Check cables are plugged into J1 and J2 correctly. Check wiring to flashhead
Red LEDs will not operate. Indicator on beacon driver module is not lit	<ol style="list-style-type: none"> <li>1. No power to Red Driver module.</li> <li>2. Faulty Red Driver module</li> </ol>	<ol style="list-style-type: none"> <li>1. Check power connections to Red Driver Module (cable in J1).</li> <li>2. Replace Module</li> </ol>

## Photocell Testing

Use the following procedure:

1. During daylight, completely block light from entering the photocell. At night, shine a light on the photocell. If the system does not transition from the present mode after a few minutes, begin the following troubleshooting steps.
2. First, disconnect the photocell from the controller. The system should go to night operation after approximately one minute.
3. If the system does not transition to night mode confirm 3.3 VDC is present on the photocell connections J4 across pins 4 and 5 with the photocell disconnected.
4. If 3.3 VDC is not present the PCB1 should be replaced.
5. If the controller changes mode correctly with the photocell removed, inspect the photocell wiring or replace the photocell. Reconnect all wires once photocell is replaced and test.

## Component Removal and Replacement

A power converter component location diagram is provided in Figure 4-2. A power converter internal wiring diagram is provided in Figure 2-20.

Note the location and color of all wires that you disconnect. When you replace the wiring after you replace the components, ensure that the wiring agrees with Figure 2-20.

The general procedures for removing components with power disconnected are as follows:

1. Obtain access to the component in question.
2. Completely remove or relocate these components.
3. Disconnect the wiring to the component that you want to replace.
4. Remove this component.
5. Replace everything in the reverse order: first the component, then the wiring. In some cases, you may have to place some wires on the component before you fasten it in place, then replace the remaining wires.

Most components are relatively easy to access for removal.

## **Section 4 – Recommended Spare & Replaceable Parts**

### ***Customer Service***

Customer Service: 1-800-821-5825

Telephone: (615) 261-2000

Facsimile: (615) 261-2600

Shipping Address:

Flash Technology  
332 Nichol Mill Lane  
Franklin, TN 37067

### ***Ordering Parts***

To order spare or replacement parts, contact customer service at 1-800-821-5825.

### ***Controller Parts***

Table 4-1 “Controller Major Replaceable Parts” lists the major replaceable parts for the controller.

### ***Power Converter Parts***

Table 4-2 “Power Converter Replacement Parts” lists the major replaceable parts for the power converter.

### ***System Parts***

Table 4-3 lists the part numbers for the major replaceable system parts that are not illustrated in the component diagrams.

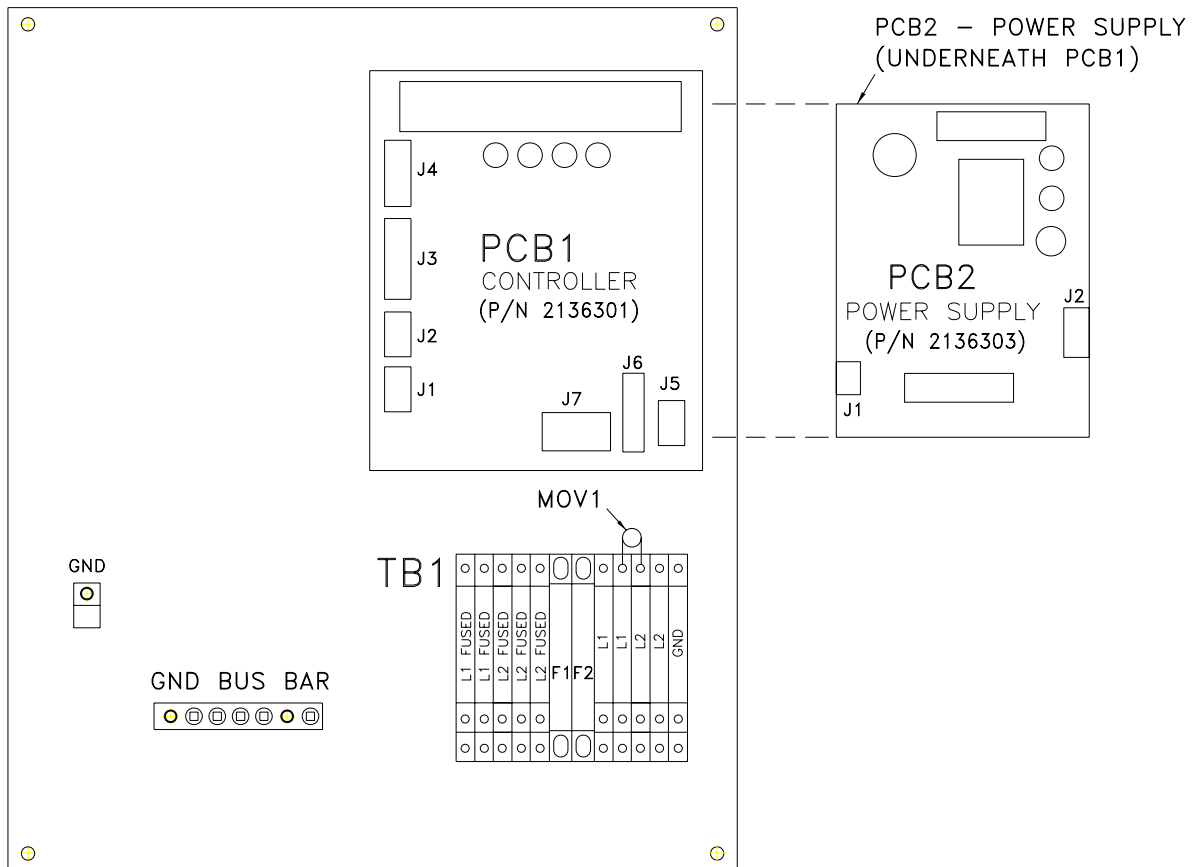

FLC 3640 (120–240VAC, 50–60HZ)  
 CATENARY – COMPONENT LOCATIONS

Figure 4-1 – FLC Controller Component Locations

Table 4-1 – Controller Replacement Parts

Reference	Description	Part Number
PCB1	PCB CONTROLLER FLC 3640 – (UNCONFIGURED)	2136301
PCB1	PCB CONTROLLER FLC 3640 – (CONFIGURED)	23624(XX) *
PCB2	PCB POWER SUPPLY FLC 3640	2136303
MOV1	►VARISTOR 230/240V METAL OXIDE	6901081
F1, F2	►FUZE 8A SLO-BLO 3AB	4362041
MOD1 FUSE	►FUZE 2A SLO-BLO 5X20MM	11000008012
-	CABLE FLC 3640 RIBBON 2 CARD SMALL	4362044
MOD1-J1	CONN 3POS PC5/3-STCL-7.62	11000008014

► Recommended as a Spare Part

\* Part number varies according to system configuration

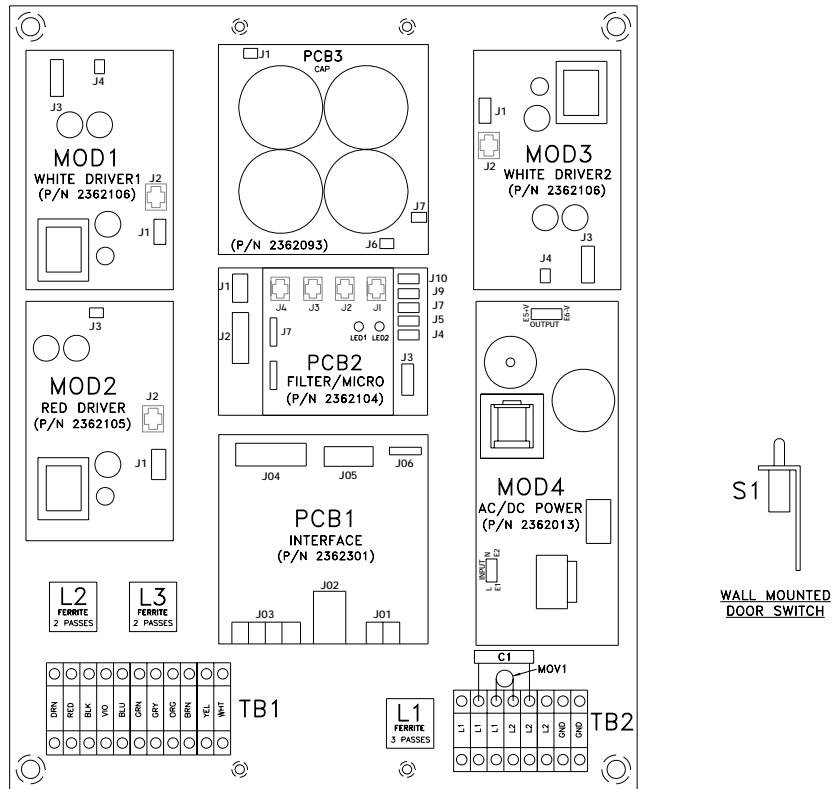

PC 3640 (120/240VAC, 50/60HZ)  
COMPONENT LOCATIONS

Figure 4-2 – Power Converter Component Locations

Table 4-2 – Power Converter Replacement Parts

Reference	Description	Part Number
PCB1	PCB INTERFACE PC 36X0	2362301
PCB2	PCB MICRO/FILTER PC 3640	2362104
PCB3	PCB CAPACITOR PC 36X0 -2	2362093
MOD1, MOD3	MODULE WHITE DRIVER PC 3640	2362106
MOD2	MODULE RED DRIVER PC 3640	2362105
MOD4	MODULE POWER SUPPLY PC 36X0	2362013
MOV1	► VARISTOR 230/240V METAL OXIDE	6901081
C1	CAP 0.1UF 250V NOISE	5362002
L1, L2, L3	FERRITE	5362001

► Recommended as a Spare Part

Table 4-3 – System Replacement Parts

Reference	Description	Part Number
FH 3640	FH 3640 L-866/L-885 LED FLASHHEAD	1362115
FH 3640	FH 3640 LIGHT ENGINE REPLACEMENT	1362116
PC 3640, FLC 3640	CABLE KIT PC 36XX RS-485 COMM, 6 FT	4362040
PC 3640, FLC 3640	CABLE 36XX RS-485 COMM, 6 FT *	4362028
PC 3640, FLC 3640	CABLE 36XX RS-485 COMM, 10 FT **	4362029
PC 3640, FLC 3640	CABLE 36XX RS-485 COMM, 15 FT **	4362030
PC 3640, FH 3640	CABLE AWG10/18 FH 3640	4362100
PC 3640, FH 3640	CONNECTOR STRAIN RELIEF EMI	5362003
PC 3640, FH 3640	NUT STRAIN RELIEF EMI	5362004
FLC 3640	PEC 510 PHOTOCELL W/20' PIGTAIL	1855001

\* Part is included with Cable Kit part number 4362040

\*\* Part is available as an alternative to 4362028

# Return Material Authorization (RMA) Policy

**IF A PRODUCT PURCHASED FROM FLASH TECHNOLOGY MUST BE RETURNED FOR ANY REASON (SUBJECT TO THE WARRANTY POLICY), PLEASE FOLLOW THE PROCEDURE BELOW:**

**Note: An RMA number must be requested from Flash Technology prior to shipment of any product. No returned product will be processed without an RMA number. This number will be the only reference necessary for returning and getting information on the product's progress.**

**Failure to follow the below procedure may result in additional charges and delays. Avoid unnecessary screening and evaluation charges by contacting Technical Support prior to returning material.**

**1. To initiate an RMA, customers should call Flash Technology's National Operations Center (NOC) at (800-821-5825) to receive technical assistance and a Service Notification number. The following information is required before a Service Notification number can be generated:**

- Site Name/Number / FCC Registration number/ Call Letters or Airport Designator
- Site Owner (provide all that apply – owner, agent or subcontractor)
  - Contractor Name
  - Contractor Company
- Point of Contact Information: Name, Phone Number, Email Address, Fax Number and Cell Phone (or alternate phone number)
- Product's Serial Number
- Product's Model Number or part number
- Service Notification Number (if previously given)
- Reason for call, with a full description of the reported issue

**2. The Service Notification number will then serve as a precursor to receiving an RMA number if it is determined that the product or equipment should be returned. To expedite the RMA process please provide:**

- Return shipping method
- Purchase Order (if non-warranty repair)
- Shipping Address
- Bill To Address
- Any additional information to assist in resolving the issue or problem

**3. A P.O. is required in advance for the replacement of product that may be under warranty. Flash will then, at its discretion issue a credit once the validity of the warranty has been determined.**

**4. A purchase order (P.O.) is also required in advance for all non-warranty repairs. NOTE: the purchase order is required prior to the issuance of the RMA number.**

- If the P.O. number is available at the time of the call, an RMA number will be issued and the customer must then fax or email the P.O. with the RMA number as the reference, to ensure prompt processing.
- If the P.O. number is NOT available at the time of the call, a Service Notification Number will be given to the customer and should be referenced on the P.O. when faxed or emailed to RMA Rep.
- Flash will then, at its discretion repair or replace the defective product and return the product to the customer based on the shipping method selected.
- The customer may purchase a new product before sending in the existing product for repair. If Flash Technology determines the existing product is still covered under warranty a credit will be issued to the customer for the new product.

**5. After receiving the Flash Technology RMA number, please adhere to the following packaging guidelines:**

- All returned products should be packaged in a way to prevent damage in transit. Adequate packing should be provided taking into account the method of shipment.

**Note: Flash Technology will not be responsible for damaged items if product is not returned in appropriate packaging.**

**6. All packages should clearly display the RMA number on the outside of all RMA shipping containers. RMA products (exact items and quantity) should be returned to:**

Flash Technology  
Attn: RMA #XXX  
332 Nichol Mill Lane  
Franklin, TN 37067

**7. All RMA numbers:**

- Are valid for 30 days. Products received after may result in extra screening and delays.
- Must have all required information provided before an RMA number is assigned.

**RETURN TO STOCK POLICY**

- **Parts can be returned within 60 days of ship date and will be subject to a 25% restocking fee. Product must:**
  - Be in the original packaging
  - Not be damaged
- **After 60 days no parts can be returned**